

USERMANUAL

LED VIDEO PIXEL LINEAR



Product Version 1.0 | Document Revision F | Released 2023-08-28

This manual covers installation, use, and maintenance of the SGM LED Video Pixel Linear. A digital version is available at www.sgmlight.com or upon request via support@sgmlight.com. The information in this document is subject to change without notice. SGM and all affiliated companies disclaim liability for any injury, damage, direct or indirect loss, consequential or economic loss, or any other loss occasioned by the use of, inability to use, or reliance on the information contained in this manual. The SGM logo, the SGM name, and all other trademarks in this document pertaining to SGM services or SGM products are trademarks owned or licensed by SGM, its affiliates, and subsidiaries.

English edition © 2023 SGM Light A/S®.

DIMENSIONS TOURING VPL

TOURING VPL 1220 20

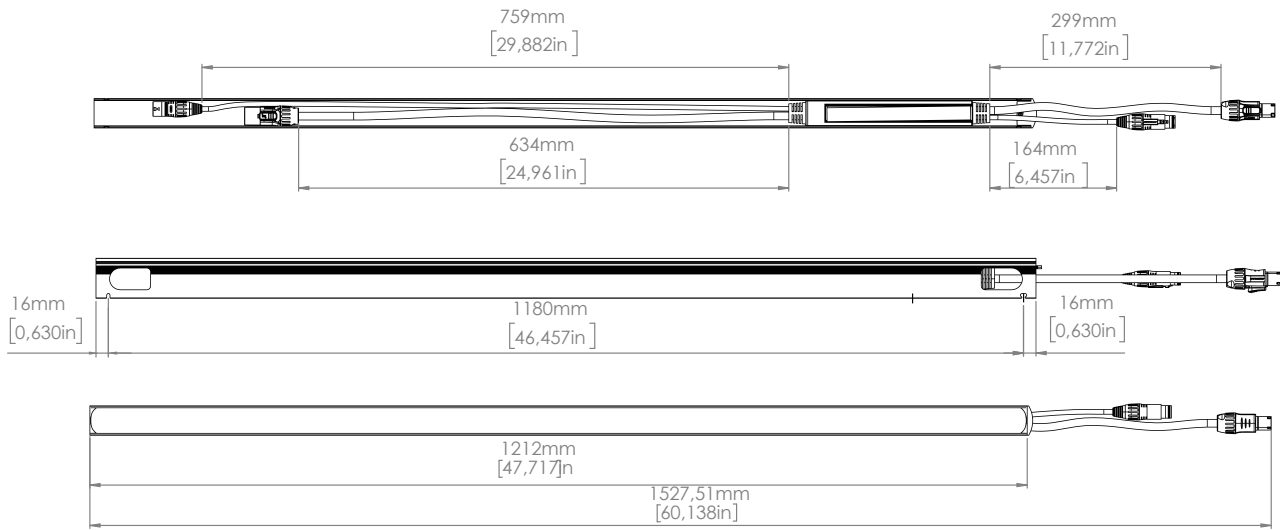

TOURING VPL 610 20

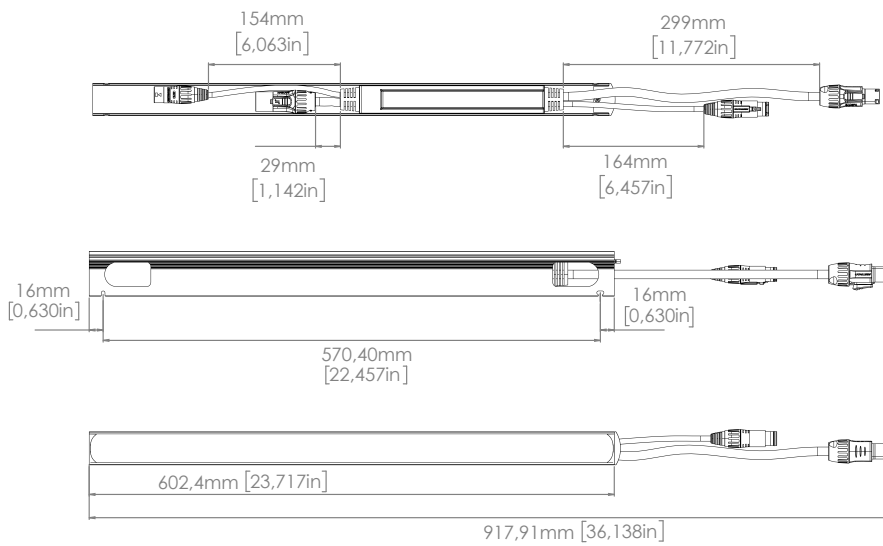

TOURING VPL 310 20

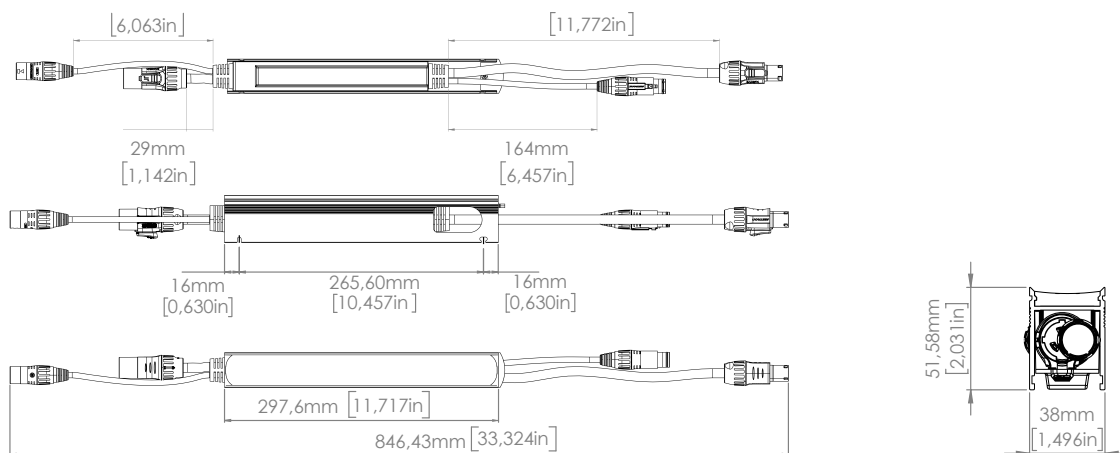

All dimensions in millimetres and inches. Drawing not to scale

DIMENSIONS POI VPL

POI VPL 1220 20

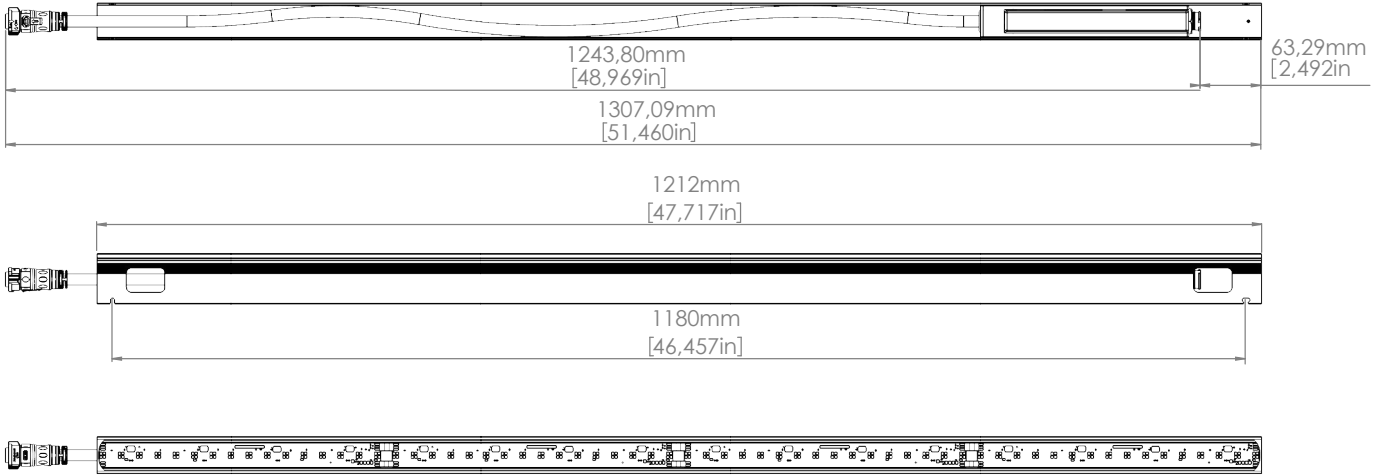

POI VPL 610 20

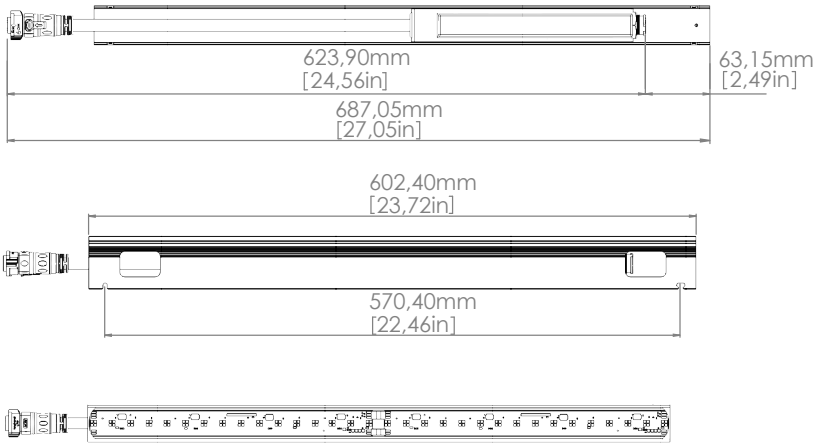

POI VPL 310 20

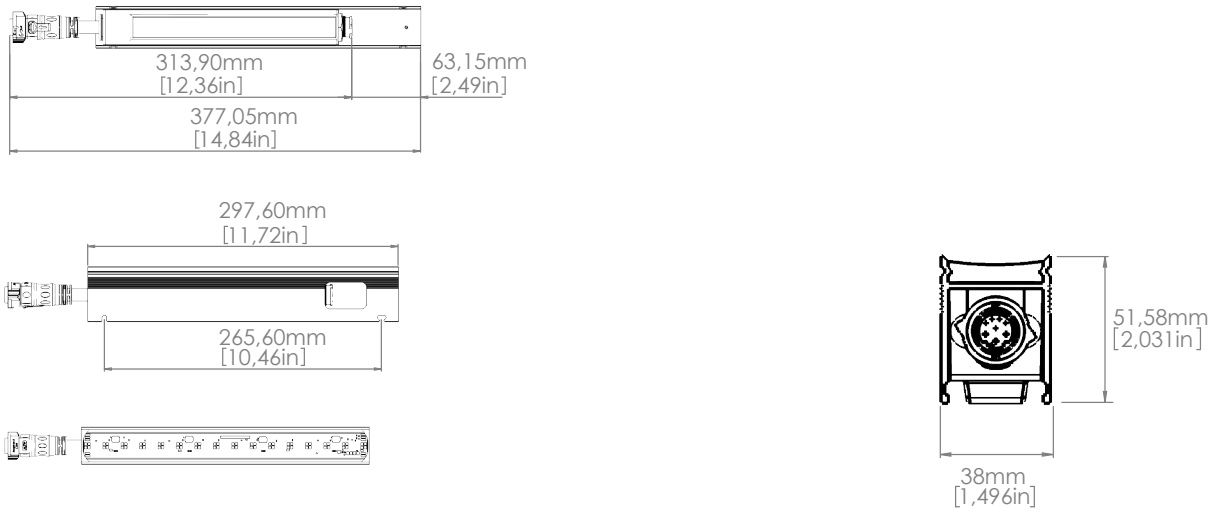

All dimensions in millimetres and inches. Drawing not to scale

Product Version 1.0 | Revision F | Released 2023-08-28

2 DIMENSIONS TOURING VPL

- 2 Touring VPL 1220 20
- 2 Touring VPL 610 20
- 2 Touring VPL 310 20

3 DIMENSIONS POI VPL

- 3 POI VPL 1220 20
- 3 POI VPL 610 20
- 3 POI VPL 310 20

6 SAFETY INFORMATION

7 BEFORE INSTALLING THIS PRODUCT

8 OVERVIEW

- 8 VPL Series
- 8 VPL variants

9 INSTALLATION TOURING VPL

- 9 Identifying Power and Data
- 9 Unpacking
- 9 Application considerations
- 9 Transport handling
- 10 Rigging process using SGM brackets
- 11 Slimline Touring Clamp with Pivot Bracket Configuration
- 12 Slimline Touring Clamp
- 13 Slimline Touring Clamp, pivot Bracket and link Plate Configuration
- 14 Temporary installations
- 14 Safety wires
- 15 Connecting Power & Data
- 15 MAXIMUM RUN LENGTH

16 TOURING VPL CONNECTORS

17 INSTALLATION POI VPL

- 17 Identifying power & data
- 17 Unpacking
- 17 Application considerations
- 17 Transport handling

19 GROUNDING OF POI FIXTURES

- 19 Installing ground wire

20 CONNECTING THE POI VPL SERIES

- 20 Permanently Connecting Power & Data
- 20 VPL Power & Data Joiner
- 21 Connect to AC power
- 22 Cable lengths
- 23 VP Connector

23 INSTALLING THE POI FIXTURES

- 23 Mounting
- 25 Replacing a fixture / De-mounting
- 26 Replacing

27	Wiring examples
30	VPL NETWORKING GUIDE
30	Network Setup
31	Universal Datagram Packet (UDP)
31	Network Size
31	FIXTURE PROPERTIES
31	Factory default
32	LENSES AND LENS ACCESSORIES
33	Removing a lens
33	Cutting a VPL lens
34	Factory Default with magnet
34	MAINTENANCE
34	Upgrading the firmware
34	Cleaning
35	FIXTURES AND ACCESSORIES
35	Ordering information
35	VPL Lenses
36	SUPPORT HOTLINE
36	APPROVALS AND CERTIFICATIONS
37	USER NOTES



WARNING! READ THE FOLLOWING SAFETY PRECAUTIONS CAREFULLY BEFORE UNPACKING, INSTALLING, POWERING OR OPERATING THE DEVICE.



SGM fixtures are intended for professional use only. They are not suitable for household use.

Les fixtures SGM sont impropres à l'usage domestique. Uniquement à usage professionnel.

This product must be installed in accordance with the applicable installation code by a person familiar with the construction and operation of the product and the hazards involved.

Ce produit doit être installé selon le code d'installation pertinent, par une personne qui connaît bien le produit et son fonctionnement ainsi que les risques inhérents.



DANGER! RISK OF ELECTRIC SHOCK DO NOT OPEN THE DEVICE!

- Do not open the device; there are no user-serviceable parts inside.
- Ensure that power is cut off when wiring the device to the AC mains supply.
- Ensure that the device is electrically connected to earth (ground).
- Do not apply power if the device or mains cable is in any way damaged.
- Do not immerse the fixture in water or liquid.



WARNING! TAKE MEASURES TO PREVENT BURNS AND FIRE!

- Install in a location that prevents accidental contact with the device.
- Install only in a well-ventilated space.
- Install only in accordance with applicable building codes.
- Do not paint, cover, or modify the device, and do not filter or mask the light.
- Keep all flammable materials well away from the device.

**ALLOW THE DEVICE TO COOL FOR 15 MINUTES AFTER OPERATION BEFORE TOUCHING IT
CAUTION: EXTERIOR SURFACE TEMPERATURE AFTER 5 MIN. OPERATION = 42°C (108°F).
STEADY STATE = 48°C (118°F).**



WARNING! TAKE MEASURES TO PREVENT PERSONAL INJURY. DO NOT LOOK DIRECTLY AT THE LIGHT SOURCE FROM CLOSE RANGE.

- Take precautions when working at height to prevent injury due to falls.
- For Permanent Outdoor Installations (POI), ensure that the fixture is securely fastened to a load-bearing surface with suitable corrosion-resistant hardware.
- For a temporary installation the standard safety wire cable must be approved for a safe working load (SWL) of 10 times the weight of the fixture, made of grade AISI 316 steel, and it must have a minimum gauge of 3mm.
- For elevated installations, secure the fixture with suitable safety cables, and always comply with relevant load dimensioning, safety standards, and requirements.

BEFORE INSTALLING THIS PRODUCT

Please visit the SGM official website at www.sgmlight.com for the latest version of this user manual/ safety information leaflet. Due to continuous improvements, the instructions may change without notice. SGM always recommends the latest available firmware version from www.sgmlight.com.



EXTERNAL CLEANING AND VISUAL INSPECTION OF THE FIXTURE

All users of the SGM fixtures should regularly clean those parts of the fixture directly exposed to the elements, such as the external housing and front lenses. Additionally, all owners of the SGM fixtures must periodically check the external housing of the fixture for structural breaks, deterioration, cracked lenses, or loose screws. To ensure proper operation, but also to prevent the risk of potential accidents, do not use the fixture if the lens, housing, or power cables are damaged. If parts of the fixture appear to be missing, cease use immediately and contact SGM support.



WIRING AND CONDUIT/ CONTAINMENT

SGM fixtures supplied with power and data cable leads are not intended for installation in permanently installed conduit or containment. When installing the fixtures in a permanent installation, ensure cable leads are installed as a service loop to an appropriately rated junction box using suitable cable strain reliefs/glands. All installed fixtures must be securely mounted, and service loop appropriately protected for installation location. All electrical wiring and connections should be completed by a qualified electrician.



SAFETY PRECAUTIONS

When using electrical equipment, basic safety precautions should always be followed including the following:

- Do not mount near gas or electric heaters.
- Permanently installed equipment should be mounted in locations and at heights where it will not be readily subjected to tampering by unauthorized personnel.
- The use of accessory equipment not recommended by the manufacturer may cause an unsafe condition.
- Do not use this equipment for other than intended use.
- Refer service to qualified personnel or authorized service centers.
- Do not look directly into the beam for long periods of time, when the fixture is on.
- The fixture shall, under no circumstance, be covered with insulating material of any kind.

READ AND FOLLOW ALL SAFETY INSTRUCTIONS.

OVERVIEW



The VPL Series is a group of "Video Pixel Linear" fixtures. Each VPL is an array of LED Quad-Pixel clusters independently controlled, designed to create powerful pixel mapping and media effects for both indoor and outdoor installations. The fixture is perfect for installations where high-visibility and very flexible setup are essential.



VPL SERIES

- Touring VPL Is an all-weather IP-65-rated fixture.
- POI VPL Is an all-weather IP-66-rated fixture.
- Touring VPL - IK08, UV and Corrosion resistant.
- VPL POI - IK09, UV and C5 Corrosion Protection
- Has 16, 32 or 64 full-color LED Quad-Pixel clusters.
- Has in-built power and data handling with no need for external power supplies or drivers.
- Is Art-Net and sACN compatible.
- Has 16 bit control with real time remote monitoring and auto addressing.
- Is available in different lengths, with optional front lenses and accessories.

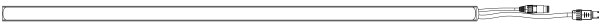
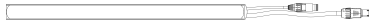
VPL VARIANTS

There are three available lengths in both Touring and POI versions of the VPL:

VPL TOURING	SIZE	LED QUAD PIXEL
1220-20	1220mm. / 4 ft. 	64 Quad pixel clusters 256 full-color LED chips
610-20	610mm. / 2 ft. 	32 Quad pixel clusters 128 full-color LED chips
305-20	305mm. / 1 ft. 	16 Quad pixel clusters 64 full-color LED chips

VPL POI	SIZE	LED QUAD PIXEL
1220-20	1220mm. / 4 ft. 	64 Quad pixel clusters 256 full-color LED chips
610-20	610mm. / 2 ft. 	32 Quad pixel clusters 128 full-color LED chips
305-20	305mm. / 1 ft. 	16 Quad pixel clusters 64 full-color LED chips

IDENTIFYING POWER AND DATA

The cables with the pins visibly showing on the smaller data connector is the “male” end and it the end which receives power and data from the supply.

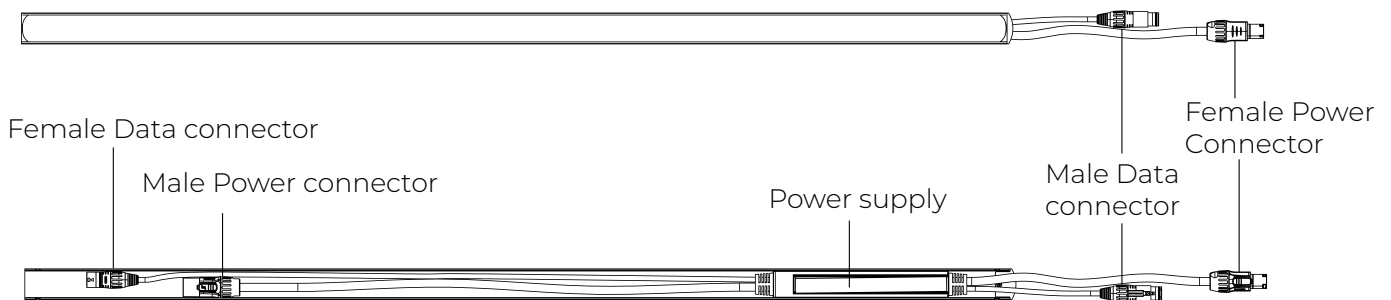

Fig. 1: Identifying Power + Data Touring VPL

UNPACKING

Unpack the device and inspect it to ensure that it has not been damaged during transportation.

APPLICATION CONSIDERATIONS

The fixture is IP66-rated and designed for both indoor and outdoor events, which completely protects the fixture from:

- Dust: to the degree that dust cannot enter the device in sufficient quantities to interfere with its operation.
- High pressure jets of water from any direction.

When selecting a location for the device, ensure that:

- It is situated away from public thoroughfares and protected from contact with people.
- It is not immersed in water.
- It has adequate ventilation.

VPL Connector End cap:

- Ensure that the last fixture's has a waterproof VPL Connector End cap installed in the female chassis connector, to maintain the IP66 rating

TRANSPORT HANDLING

- Always use the supplied packaging or suitable flight case for transportation and storage.
- Never carry the fixture by connected cables or wires!

RIGGING PROCESS USING SGM BRACKETS



Figure 2: Standard Touring Clamp

(P/N: 83060633) Standard Touring Bracket

This bracket is for temporary setups without the need for tools. It has a snap-on sliding action for quick release and easy setup. It has several threaded attachment points for generic third-party pipe couplers or other standard hardware.

When using touring brackets, always secure every VPL with a safety wire, attached to the fixture's highest point.



Figure 3: Slimline Touring Clamp

[P/N: 83060722] Slimline Touring Clamp

This bracket features a minimal size and visibility in direct view applications. It is sliding only (not snap-on) bracket which is assembled and secured using a standard m4 hex or allen driver and is compatible with the swivel bracket and link plate.



Figure 4: Pivot bracket

[P/N: 83060718] Pivot Bracket

Milled aluminum bracket with anodized finish and connection hardware included. Part of the Touring VPL connection system to enable shapes, angles, and flexible designs to be rigged on temporary installations.

Designed for use with the slimline touring bracket, it bridges two touring VPLs to make complex shapes

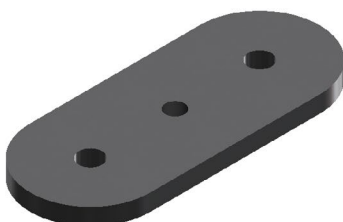
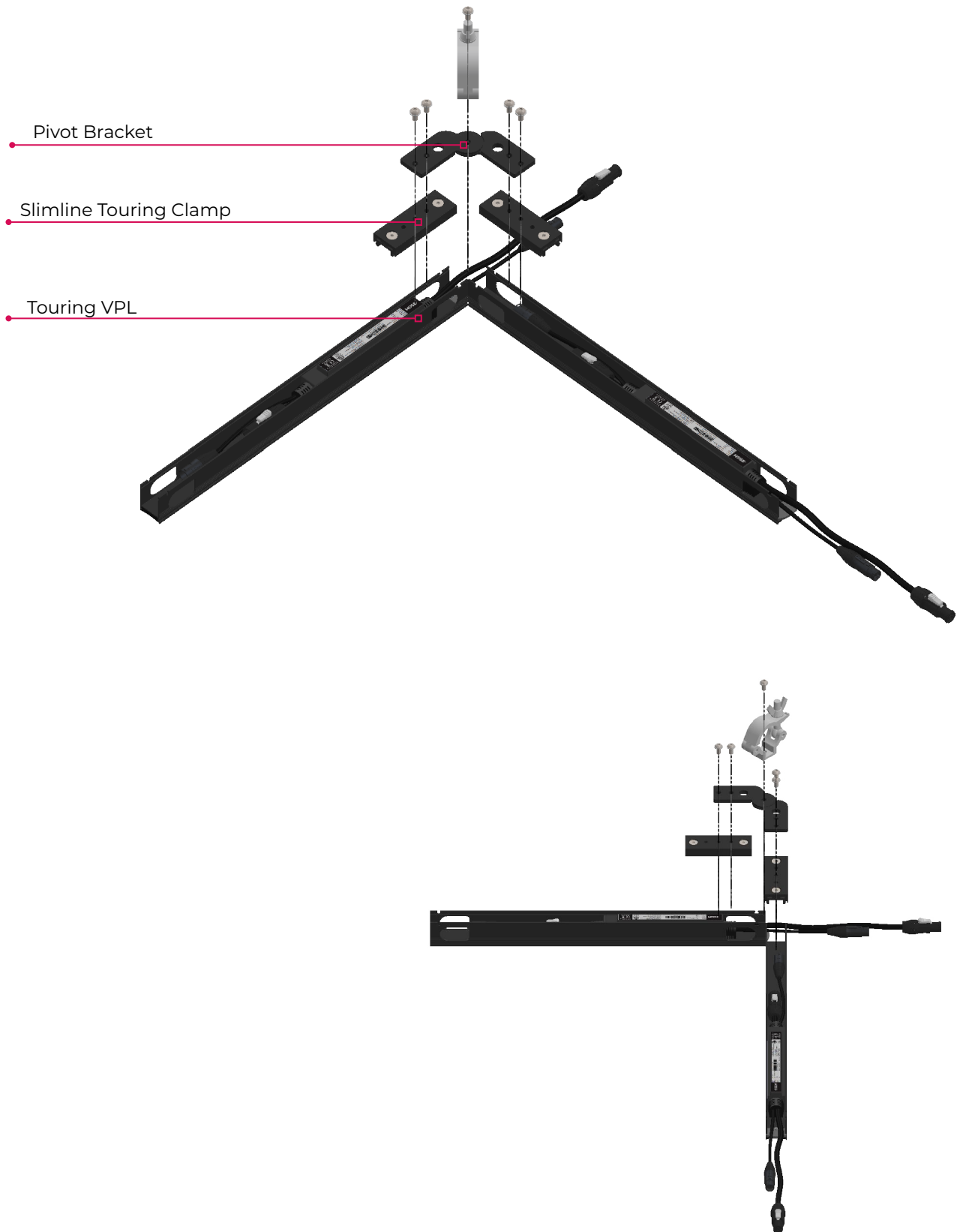

Figure 5: Link plate

[P/N: 83060717] Link Plate

Milled aluminum bracket with anodized finish and connection hardware included. The link plate bridges two Pivot Brackets, enabling intersections of multiple VPLs with one connection point to a truss or support structure.

SLIMLINE TOURING CLAMP WITH PIVOT BRACKET CONFIGURATION



SLIMLINE TOURING CLAMP

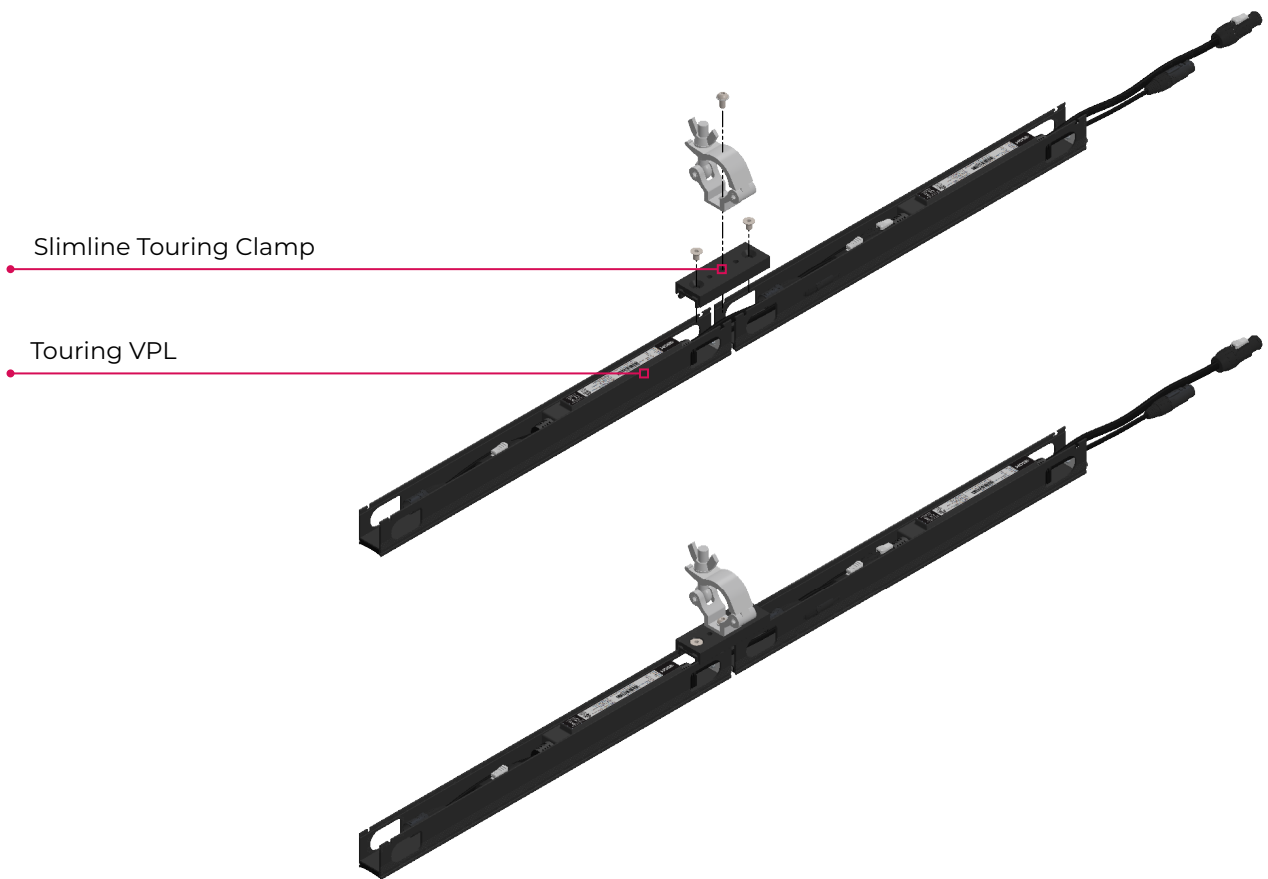
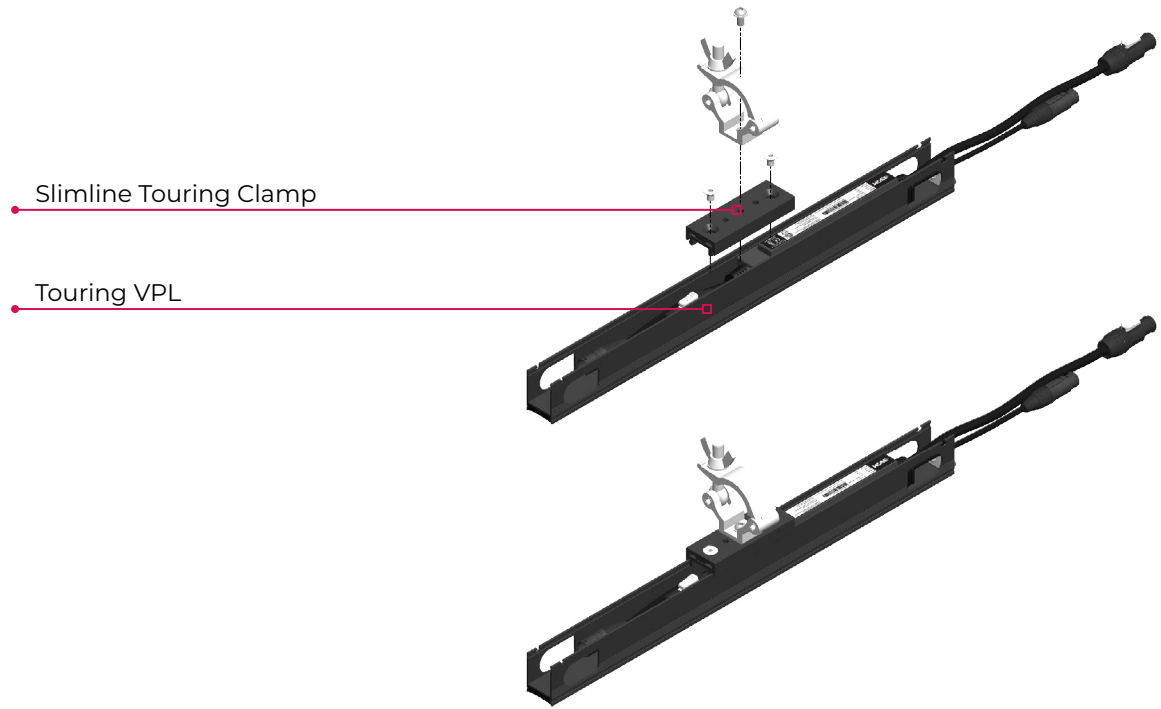

SLIMLINE TOURING CLAMP, PIVOT BRACKET AND LINK PLATE CONFIGURATION

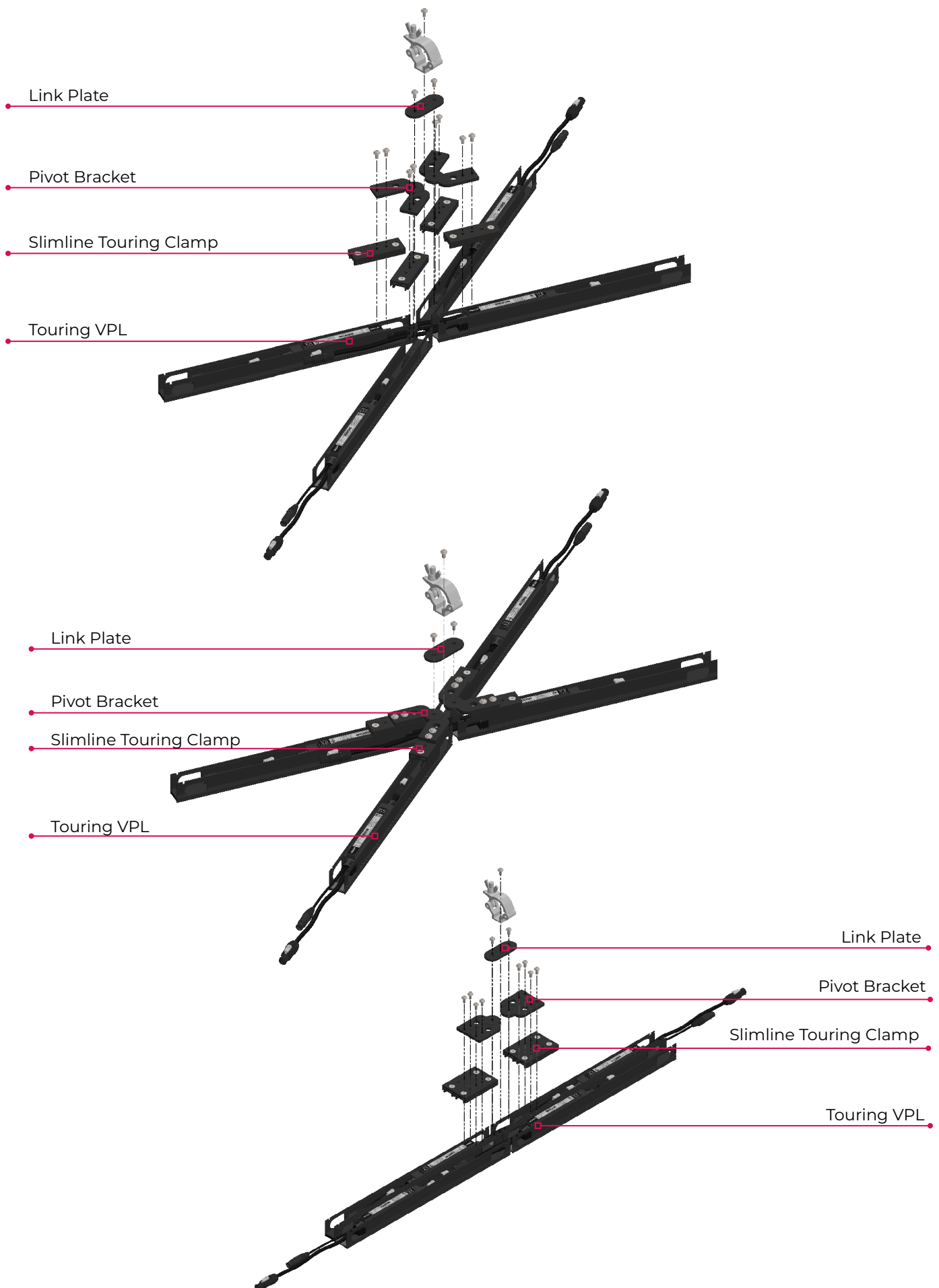

TEMPORARY INSTALLATIONS

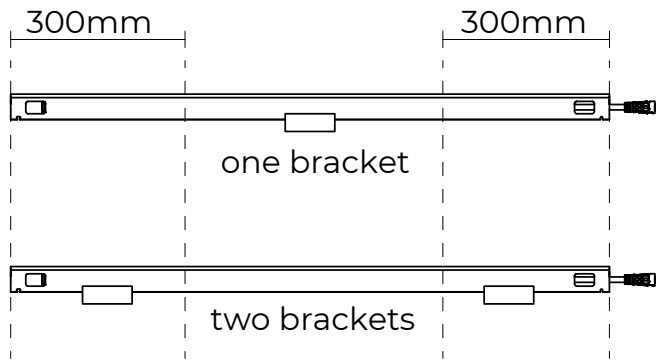

The Touring Bracket is designed for temporary installations and rental applications. It is a versatile bracket, meant for attachment to truss or pipes. A VPL Single Touring bracket can carry a SGM VPL 1220-20 if it is placed no more than 300 mm away from either end of a VPL. (see figure 6).

Figure 6: Bracket guide-line, if the bracket is closer to than 300mm to the edge, two brackets are advised.

SAFETY WIRES

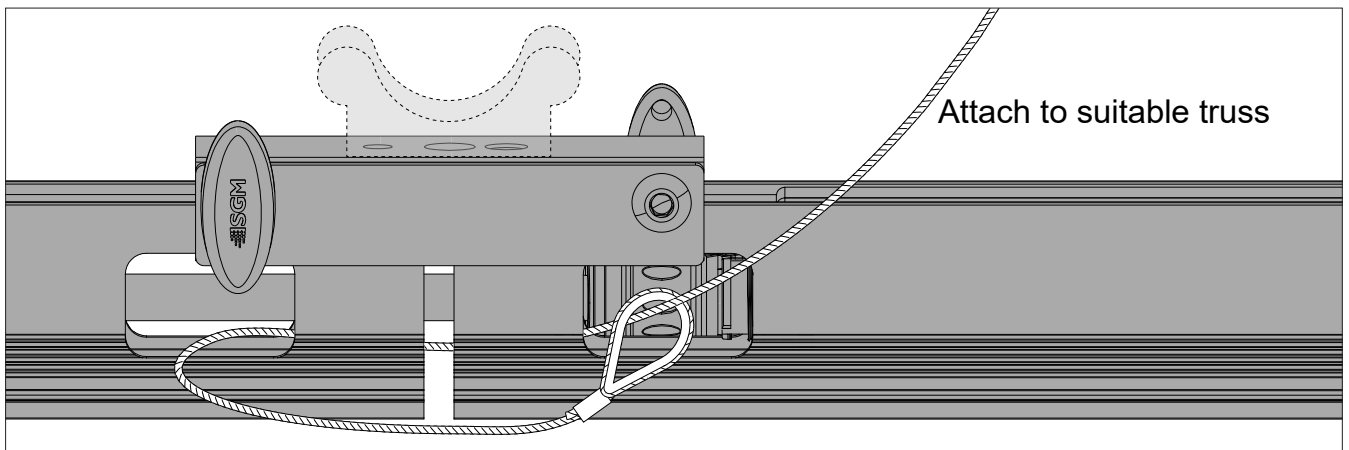

Figure 7: Attaching safety wire through the holes in the VPL profiles.

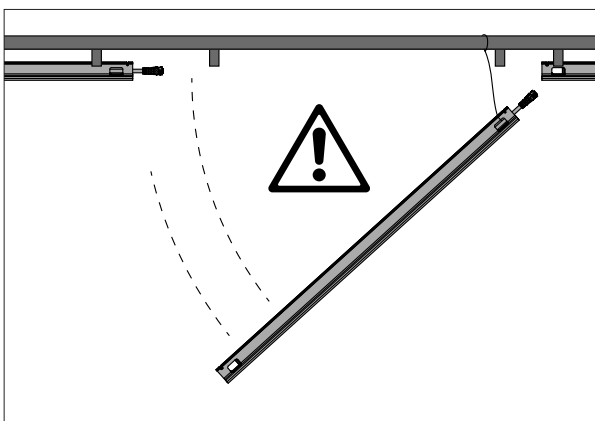

Figure 8: Attach the safety wire in both sides.

The safety wire should be installed at the highest point on the VPL to minimize the fall distance. When installing VPLs in ceilings or any horizontal plane with people below, make sure to install one safety wire in both ends of the VPL (see figure 8). If the fixtures are installed as an extension of each other, one safety wire can be attached to two adjacent fixtures (see figure 7).



WARNING! ALWAYS INSTALL A SAFETY WIRE ON BOTH ENDS WHEN USING VPLS IN A CEILING INSTALLATION. THE VPLS SHOULD ALWAYS BE PROPERLY FIXED AND NOT HUNG IN THE CABLES.

CONNECTING POWER & DATA

The VPL Series can operate on any 200–240 V, 50/60 Hz AC mains power supply. Power and data connects to Touring VPL via the Powercon and Ethercon type connectors. See figure below for wiring diagram.

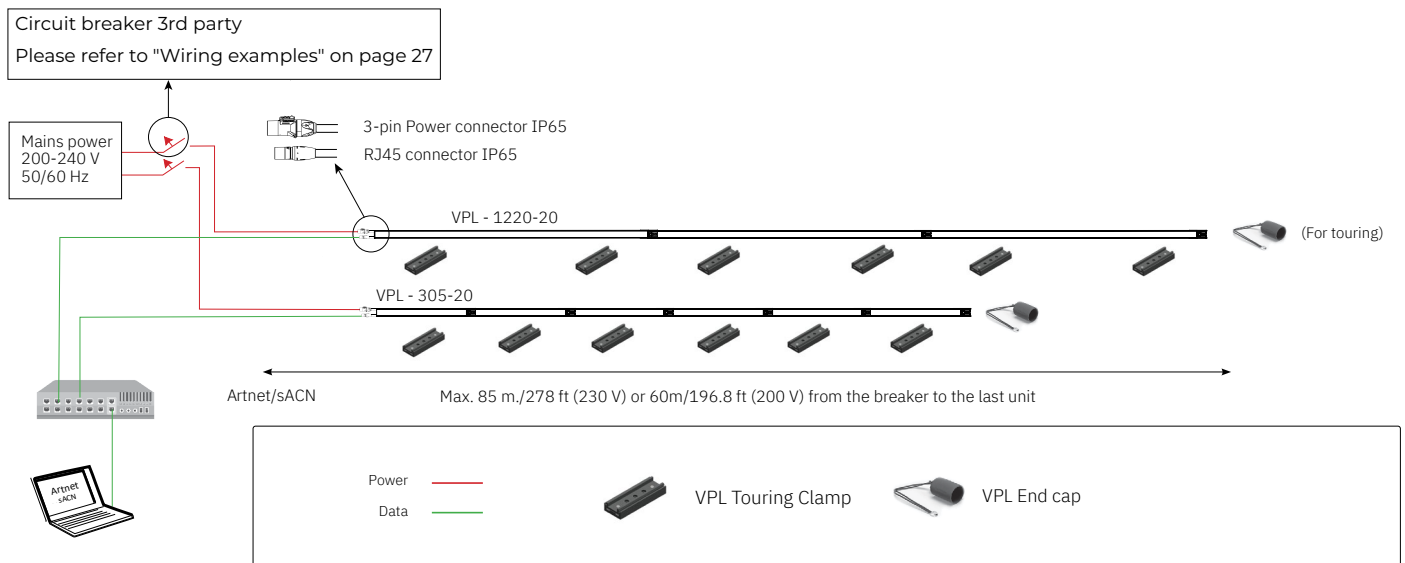

Figure 9: VPL Connection diagram

PLEASE NOTE! FOR SPECIAL INSTALLATIONS WITH MORE VPL STRINGS IN COMBINATION WITH MORE CABLE LENGTHS IN BETWEEN, PLEASE CONTACT YOUR DISTRIBUTOR OR SGM SUPPORT.

MAXIMUM RUN LENGTH

Total maximum run length of all VPLs and feed or leader cable is a function of the total number of VPLs and the total of all power and data extensions in one run.

TOURING VPL CONNECTORS

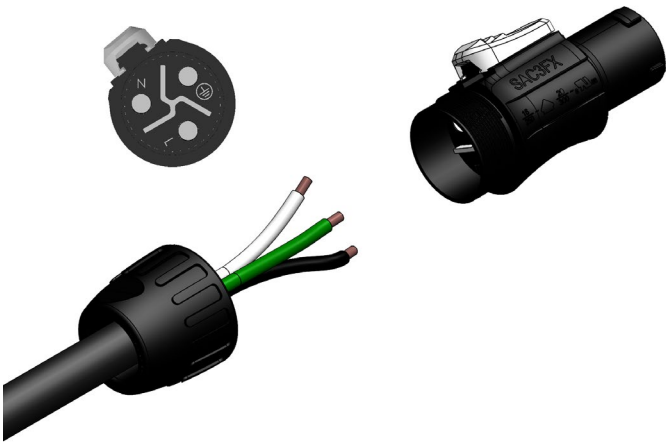

PIN ID	COLOR
N	White
L	Black
Earth	Yellow/Green

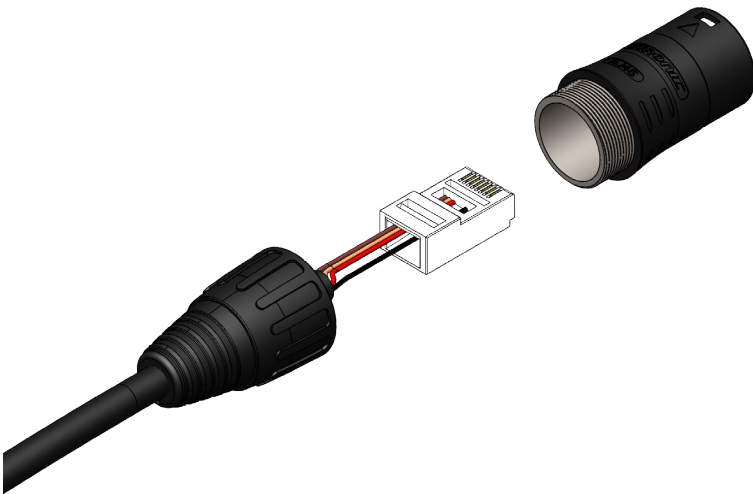

PIN N#	COLOR
Pin 1	Brown
Pin 2	Orange
Pin 3	Red
Pin 6	Black

IDENTIFYING POWER & DATA

The VP cable with the male connector is the flexible cable which extends from the power supply, while the female VP data connector is mounted directly into the power supply (see figure 10).

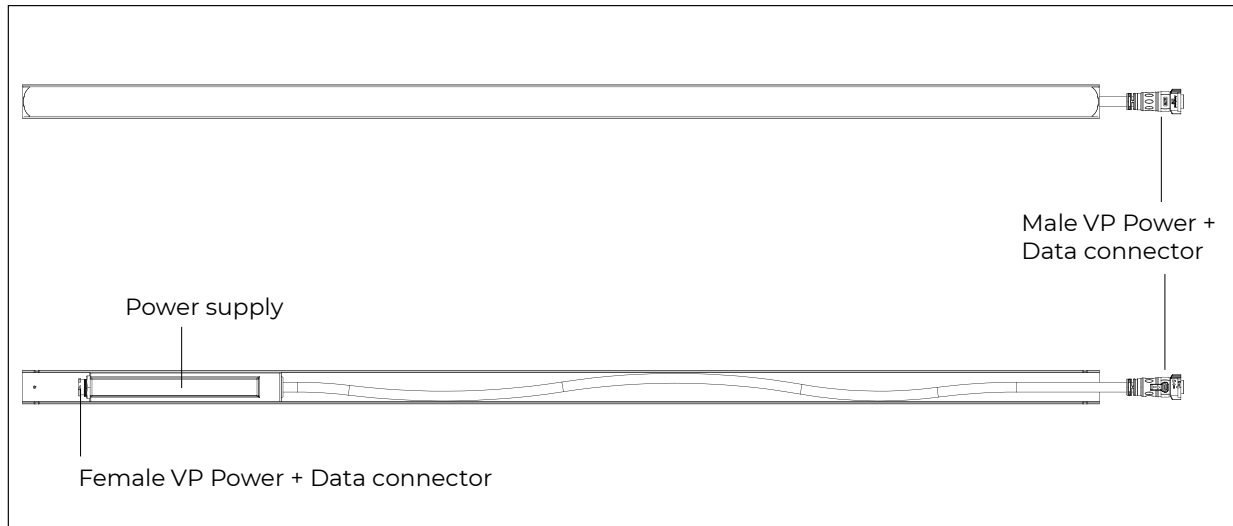

Figure 10: Identifying Power + Data

UNPACKING

Unpack the device and inspect it to ensure that it has not been damaged during transportation.

APPLICATION CONSIDERATIONS

The fixture is IP66-rated and designed for both indoor and outdoor events, which completely protects the fixture from:

- Dust: to the degree that dust cannot enter the device in sufficient quantities to interfere with its operation.
- High pressure jets of water from any direction.

When selecting a location for the device, ensure that:

- It is situated away from public thoroughfares and protected from contact with people.
- It is not immersed in water.
- It has adequate ventilation.

VPL Connector End cap:

- Ensure that the last fixture's has a waterproof VPL Connector End cap installed in the female chassis connector, to maintain the IP66 rating

TRANSPORT HANDLING

- Always use the supplied packaging or suitable flight case for transportation and storage.
- Never carry the fixture by connected cables or wires!



ALWAYS SECURE EVERY VPL WITH A SAFETY WIRE WHEN USING THE VPL TOURING BRACKET.

The Single Installation Bracket (P/N: 86060634) is intended for single ends of VPLs, arranged in a parallel array (see figure 11)

The VPL Dual Installation Bracket (P/O: 83060635) is intended for installing the fixtures in a physical series connection (see figure 12). The VPL Dual Installation Bracket will maintain the pixel pitch of 20mm.

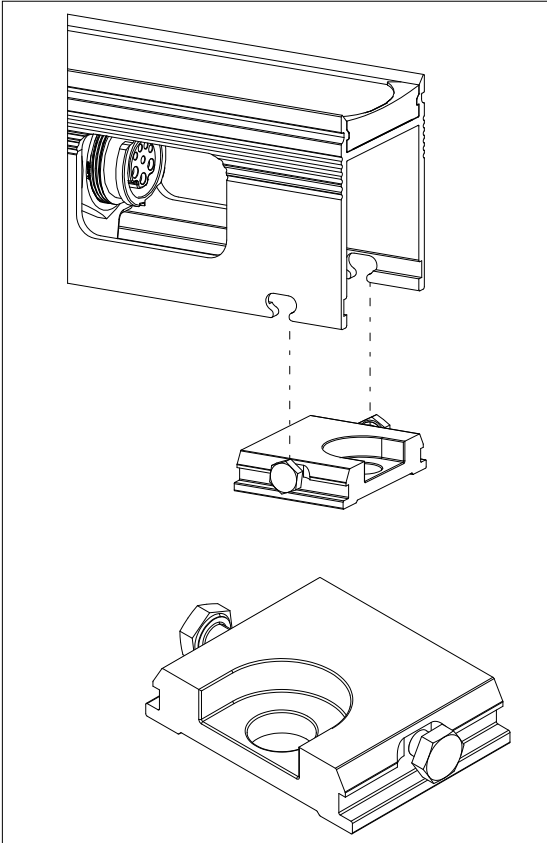

Figure 11: Single bracket

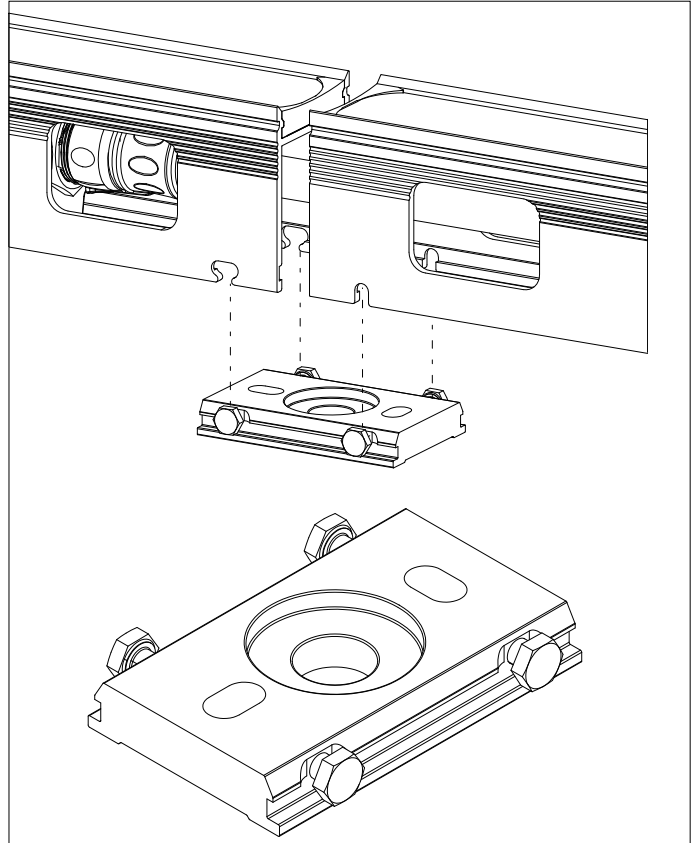

Figure 12: Dual bracket

PLEASE NOTE! UNDERSTANDING AND CHOOSING THE RIGHT BRACKET IS CRUCIAL FOR SAFETY. FOR PERMANENT INSTALLATIONS, THE VPLS SHOULD ALWAYS BE MOUNTED WITH AT LEAST TWO BRACKETS.

GROUNDING OF POI FIXTURES

When installing VPLs on the exterior of high buildings it is always recommended to ground the individual fixtures to the building to minimize the risk of failure due to lightning strikes. Make sure to check the local building code for possible directives or laws regarding lightning prevention.

INSTALLING GROUND WIRE

The GND/Earth Cable kit (P/N: 83062050) contains one ground wire (Green and yellow wire with a ring terminal, 1 meter) and one M3 nut with a star washer, which fits on the bolt near the female VP connector on the VPL. Remember to apply cavity wax after mounting the ground wire to prevent corrosion (see figure 13 and 14).

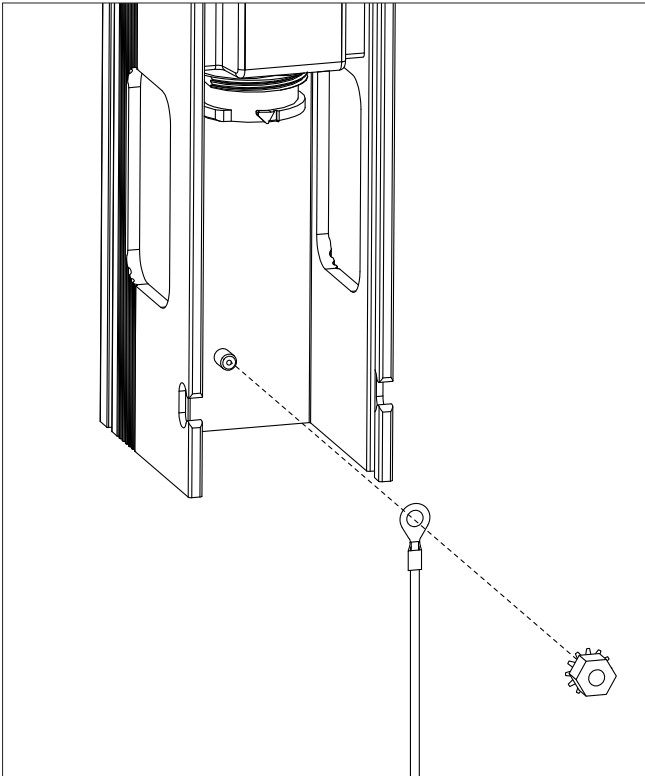

Figure 13: Attach cable and nut

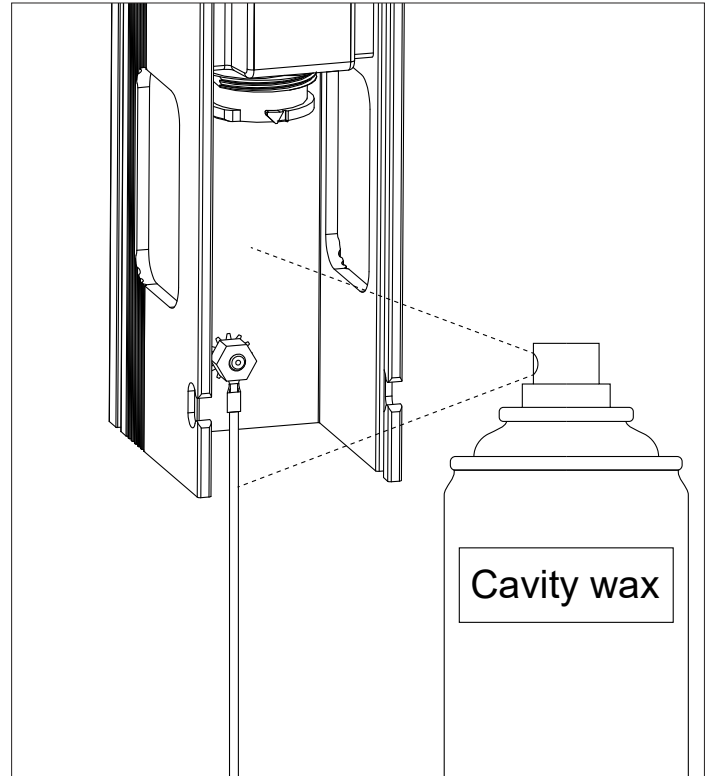

Figure 14: Apply Cavity wax

CAUTION!

ALWAYS WEAR APPROPRIATE PERSONAL PROTECTION ACCORDING TO THE CAVITY WAX PRODUCERS INSTRUCTIONS.

PERMANENTLY CONNECTING POWER & DATA

The VPL Series can operate on any 200–240 V, 50/60 Hz AC mains power supply. Power is connects to the fixture via a Power+Data joiner or inserter (not included) (see figure 15 for connection diagram).

VPL POI must be plugged together before power is switched on. If a VPL needs to be replaced in a line, power must be switched off before doing so.

PLEASE NOTE! BEFORE CONNECTING / DISCONNECTING VPL'S FROM THE INSTALLATION MAKE SURE THE MAINS POWER IS SWITCHED OFF.

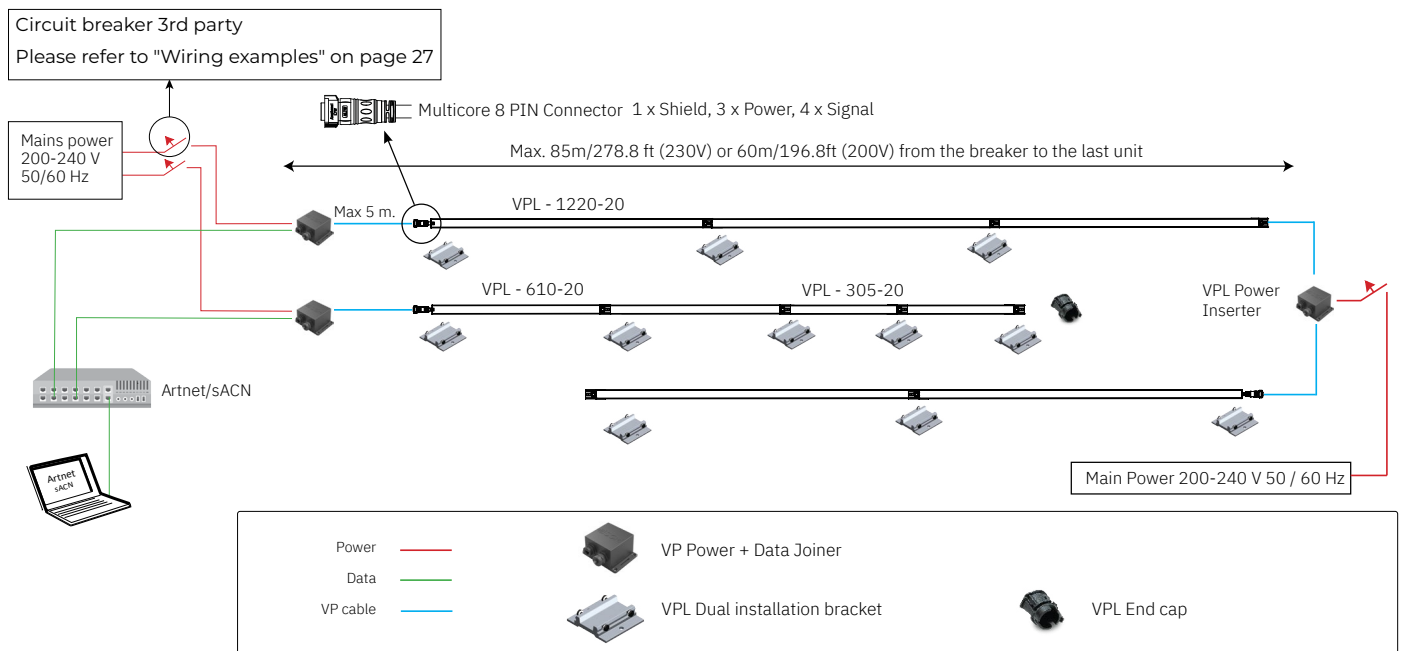

Figure 15: VPL Connection diagram

PLEASE NOTE! FOR SPECIAL INSTALLATIONS WITH MORE VPL STRINGS IN COMBINATION WITH MORE CABLE LENGTHS IN BETWEEN, PLEASE CONTACT YOUR DISTRIBUTOR OR SGM SUPPORT.

VPL POWER & DATA JOINER

The VP Power + Data Joiner (see figure 16) is designed to join power and data for a daisy chain of VP fixtures. One VP Power + Data Joiner can send power and data up to 65 VPL 1220-20 units at 240 volts and 45 units at 208 volts. It is recommended to install a 10amp type B circuit breaker for each string of cabled VPL fixtures.

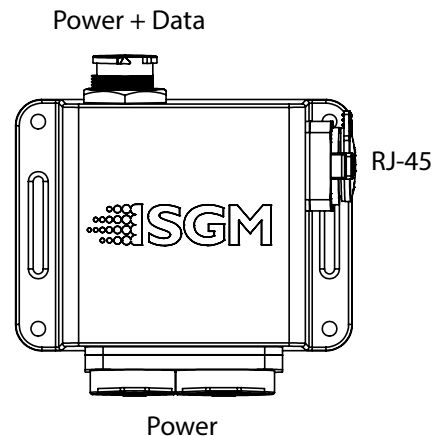

Figure 16: VPL Power + Data Connector

CONNECT TO AC POWER

Connect the fixture to AC power using a SGM Power + Data joiner (not included) or similar. To ensure the correct ingress protection (IP-rating), always use the SGM VP cables, and waterproof RJ-45 kit (see figure 17)

Order number: (83062057).

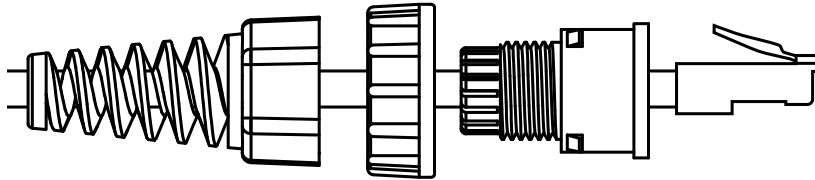

Figure 17: Waterproofing an RJ-45

The power cable must be grounded/earthed, and the AC power supply must incorporate a 10 amps type B circuit breaker for fault protection.

For a temporary outdoor installation, the power cable must be fitted with a grounded connector intended for exterior use.

For permanent installations, have a qualified electrician to wire the power cable directly to a suitable branch circuit. All cabling and distribution ingress protection (IP) rating must be suitable for the location.



WARNING! ALWAYS ENSURE THAT THE INSTALLATION DOESN'T EXCEED THE MAXIMUM CAPACITY IN A DAISY-CHAIN.

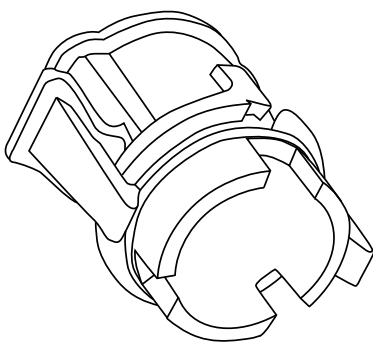

Figure 18: VP End Cap

PLEASE NOTE! THE BUILT-IN PROTECTIVE CAPS MUST BE SECURELY MOUNTED ON ANY UNUSED POWER OR DATA CONNECTORS, AND VP END CAPS (SEE FIGURE 18) INSTALLED IN THE UNUSED FIXTURE'S VP CONNECTORS THE FIXTURES, IN ORDER TO MAINTAIN THE IP-RATING.

CAUTION!

DO NOT CONNECT THE FIXTURE TO AN ELECTRICAL DIMMER SYSTEM, AS DOING SO MAY CAUSE DAMAGE AND VOID WARRANTY.

CABLE LENGTHS

SGM offers 3 lengths of extension cable; 1m (3.2 ft), 2.5m (8.2 ft.) and 5m (16.4 ft.). However, it is possible to purchase a Custom Extension Cable Kit in either 1m (3.2 ft) or 10m (32 ft.) (1m: P/N 83062054, 10m P/N 83062055), and the Crimping tool for VP connectors(P/N 83062301), to make cables of any length. The cables have one moulded connector while the other end is ready to be cut in the desired length. Note that only one cable can be made from each Custom Extension Cable Kit, and that the Crimping tool is necessary to install the adapters.

1. Cut the cable in the desired length
2. Disassemble the X-lok connector and lead the cable through the seal cap (see figure 19).
3. Strip the cable with suitable tools. The exposed copper wire should be 9-11mm (see figure 20).
4. Mount the crimping pins and use the VP Crimping tool (see figure 21) to securely fasten them. The power cables use AWG 16 pins while the data pins use AWG 26.
5. Insert the crimped pin in the clamp ring according to the illustration in figure 22.

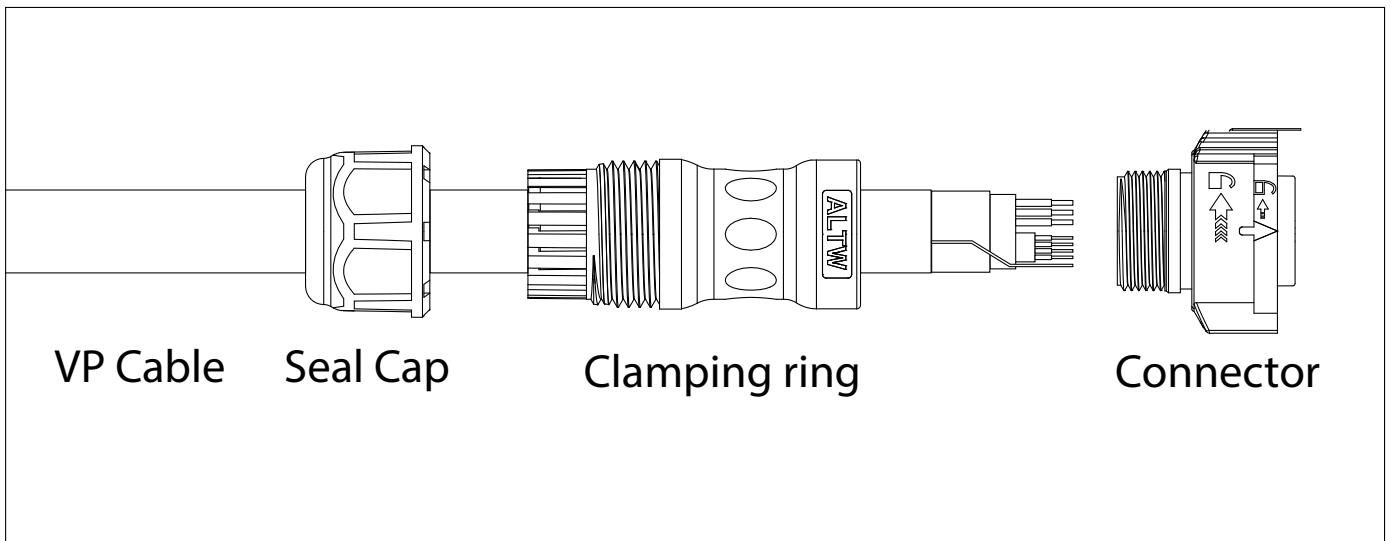

Figure 19: X-lok parts

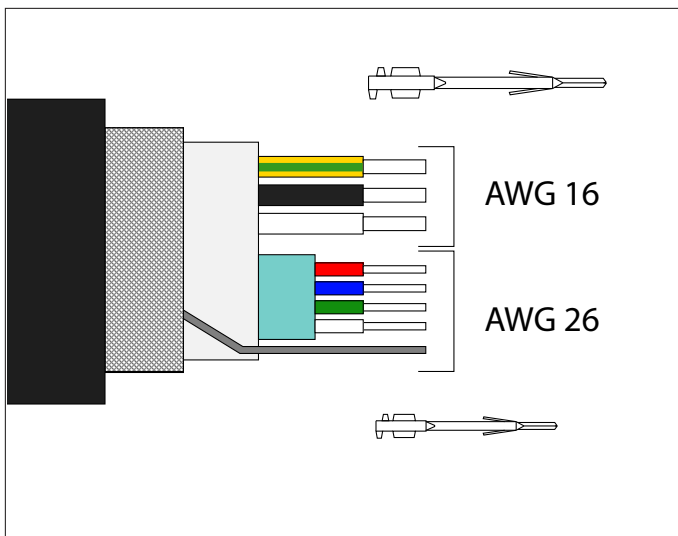

Figure 20: VP Cable

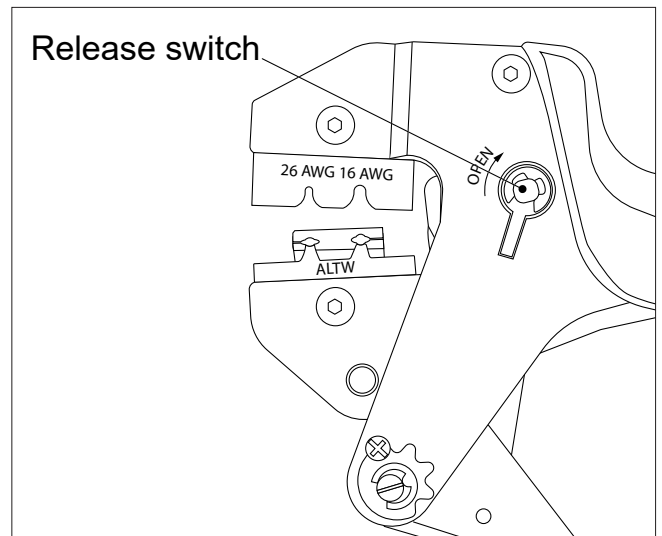
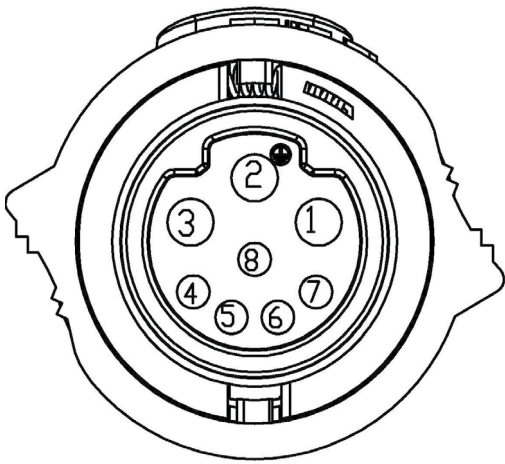

Figure 21: VP Crimping tool

PLEASE NOTE! THE VP CRIMPING TOOL CAN ONLY OPEN AFTER COMPLETELY PRESSING THE TOOL, OR SWITCHING THE RELEASE SWITCH. DO NOT FORCE IT!

VP CONNECTOR

The VPL Series has a female multi-core 8 pin cable located in the first end of the VPL, and a male multicore 8 pin connector in the last end of the VPL. The 8 pins are divided by 1xShield, 3xPower, 4xSignal (see figure 18).



- 1 — Power - White
- 2 — Power - Yellow/Green
- 3 — Power - Black
- 4 — Data - White
- 5 — Data - Green
- 6 — Data - Red
- 7 — Data - Blue
- 8 — Data - Shield

Figure 22: VPL female connector

Wire	Color	Symbol	Conductor
	Black	L	live
	White	N	neutral
	green/yellow	⊥ or ⊕	ground (earth)

The power cable color coding:

- Connect the black wire to live
- Connect the white wire to neutral
- Connect the green/yellow wire to ground (earth)

Figure 23: Power cable color code

INSTALLING THE POI FIXTURES

MOUNTING

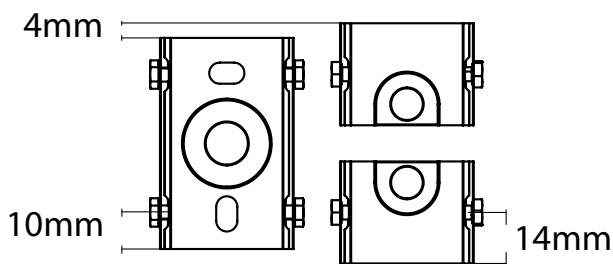

The recommended way to install VPLs and brackets is to install one at the time. Although it is possible to mount the brackets first, the inherent expansion and contraction of the aluminium profiles, from which the VPLs are made, can cause complications where temperatures may vary.

PLEASE NOTE! WHENEVER SINGLE AND DUAL BRACKETS ARE USED AT THE SAME TIME REMEMBER TO TAKE THE SIZE DIFFERENCE INTO CONSIDERATION

Step 1

Draw the linear path guide-lines for the VPLs and install the first bracket

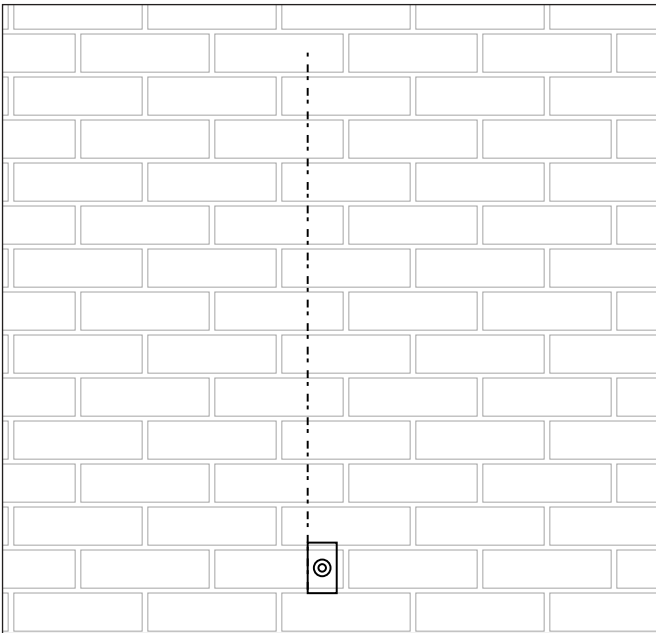

Step 2

Attach a second bracket to the VPL at the end with the oblong hole, by clicking it into place.

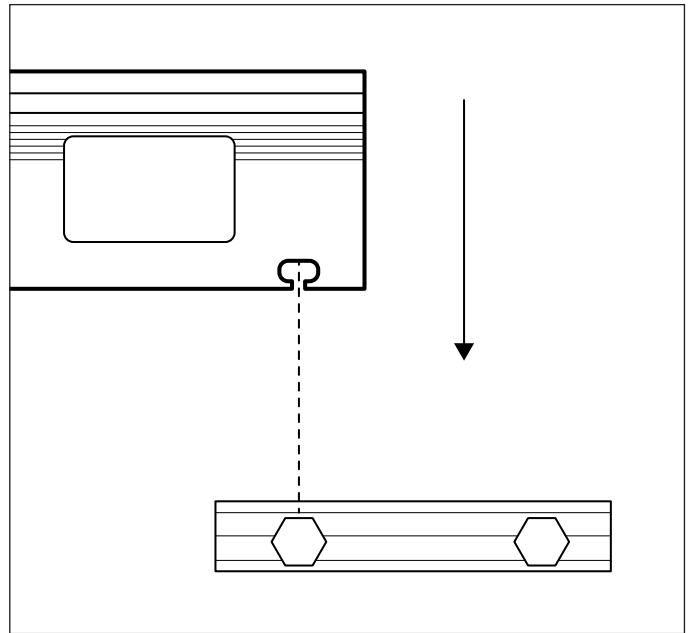

Step 3

Click the VPL into the installed bracket. Remember to tighten the bolts.

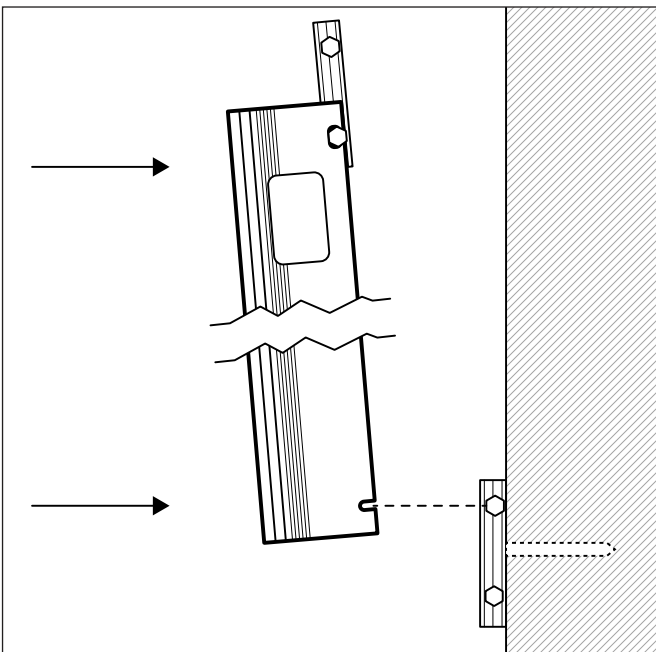

Step 4

Align the VPL to the guides and adjust the bracket so the bolts are centered in the oblong hole. This will prevent thermal expansion difficulties.

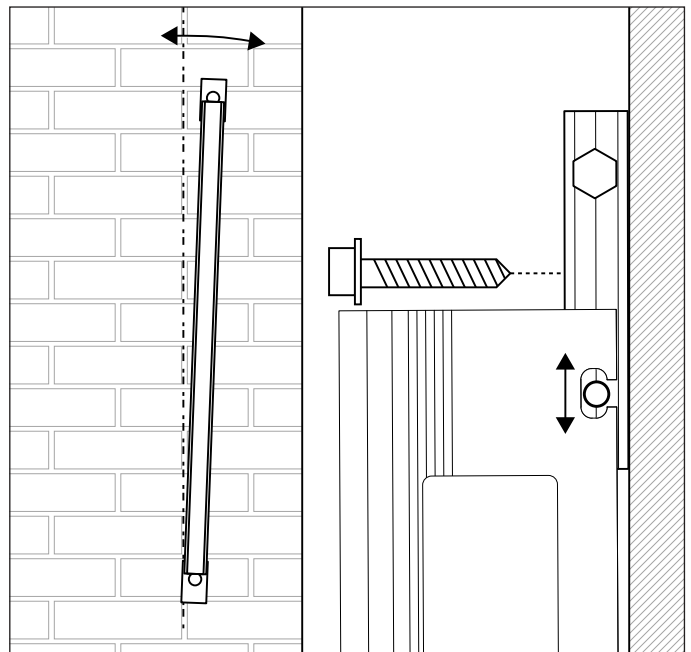

REPLACING A FIXTURE / DE-MOUNTING

Step 1

Loosen the bolts while holding the profile and begin to loosen the single hole side bracket.

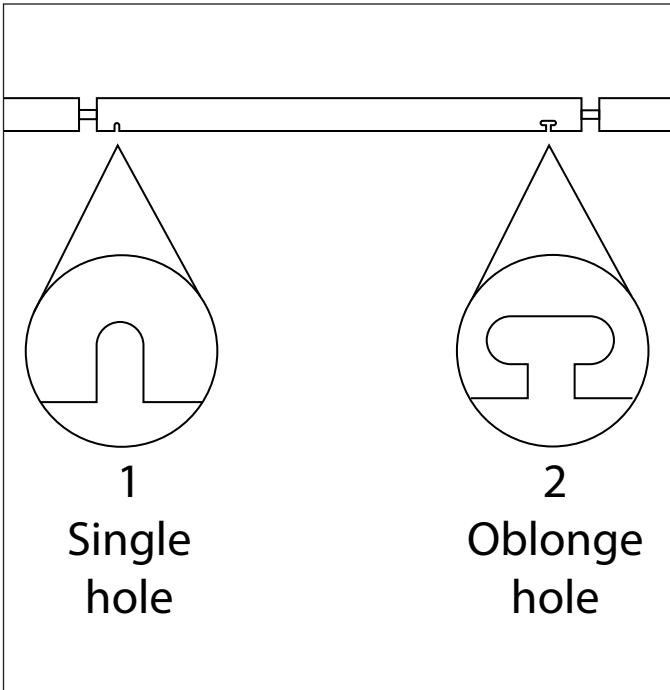

Step 2

Remove the VPL by carefully twisting the profile off the bracket. You can get a grip through the hole near the connector.

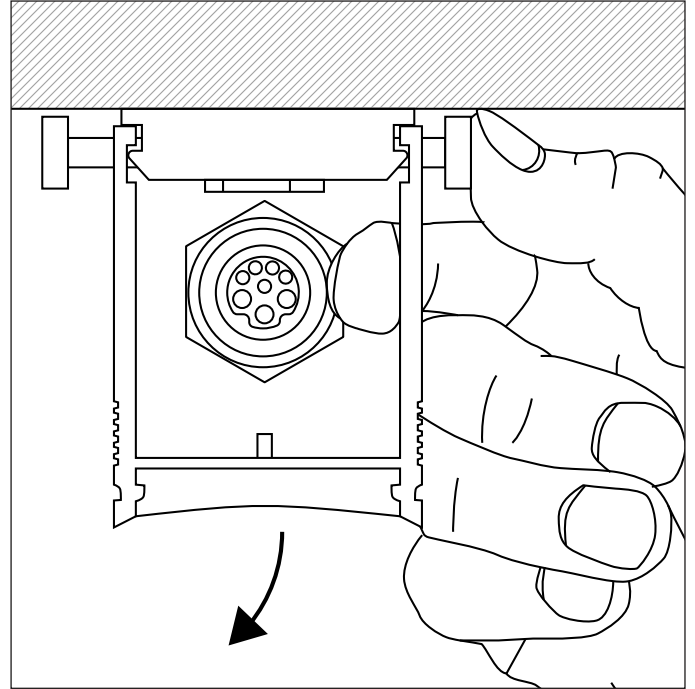

Step 3

When the profile is free, remove the VP cable starting with the lower cable, and remove the fixture.

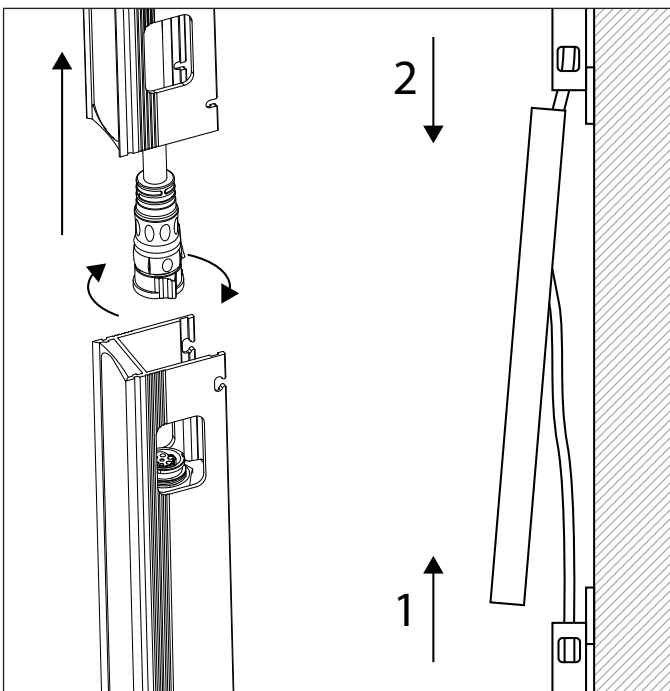

REPLACING

Step 1

Insert the power/data cable and ensure that it is connected properly with a click sound on insertion. Confirm the alignment of the arrows.

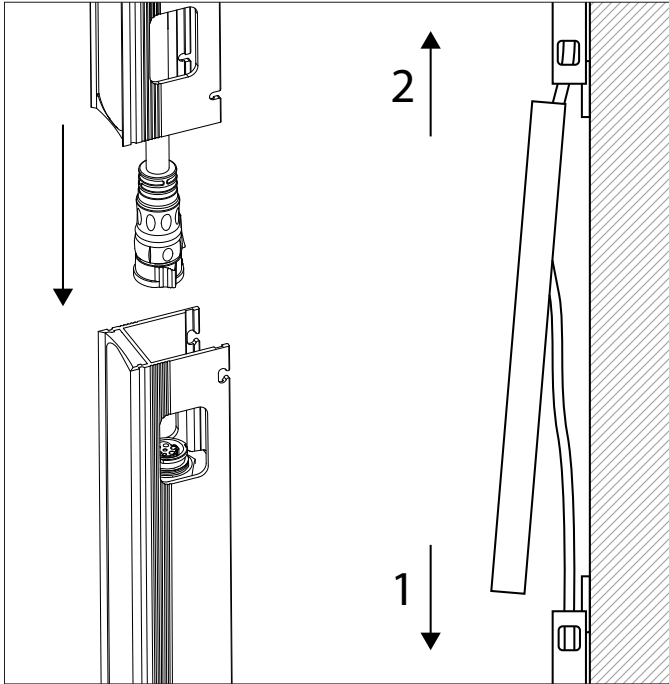

Step 2

Click the VPL into the brackets with the oblong hole first and the single one after. Tighten the bolts after installation.

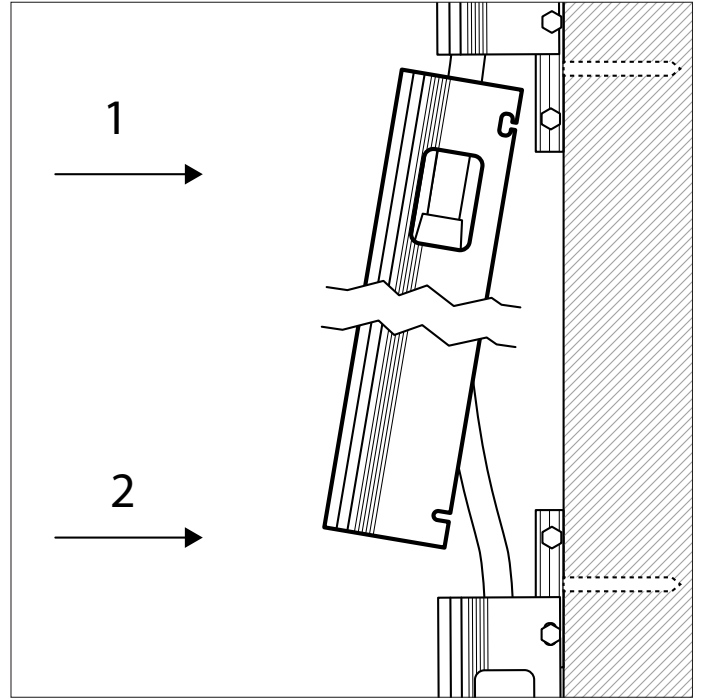

WIRING EXAMPLES

208 VAC/15A - WIRING EXAMPLE TOURING VPL 1220/4FT

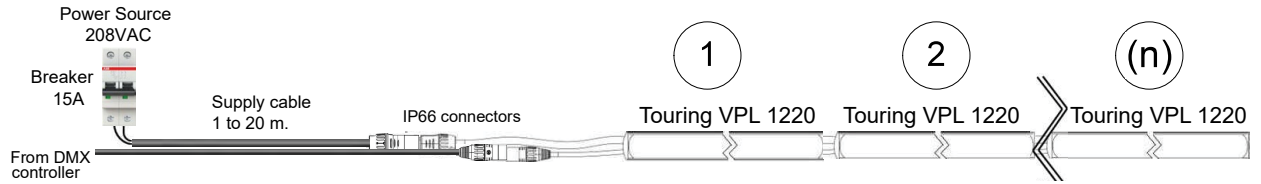

(n) Maximum number of units on a Breaker line				27W		
Power Source nominal voltage	Power Source Shortcircuit current	Cable between Breaker and 1. unit	Cable between each unit	Breaker type 15AC	Breaker type 15AB	Breaker type 15AZ
208 [V]	250 [A]	1 [m]	0 [m]	19	65	65
208 [V]	1000 [A]	1 [m]	0 [m]	43	65	65
208 [V]	250 [A]	10 [m]	0 [m]	12	64	65
208 [V]	1000 [A]	10 [m]	0 [m]	35	65	65
208 [V]	250 [A]	1 [m]	2,5 [m]	7	24	65
208 [V]	1000 [A]	1 [m]	2,5 [m]	15	32	65
208 [V]	250 [A]	10 [m]	2,5 [m]	4	22	65
208 [V]	1000 [A]	10 [m]	2,5 [m]	12	29	65

Optional: Extension cable Between units

Optional: Extension cable Between units

208 VAC/15A - WIRING EXAMPLE TOURING VPL 1220/2FT

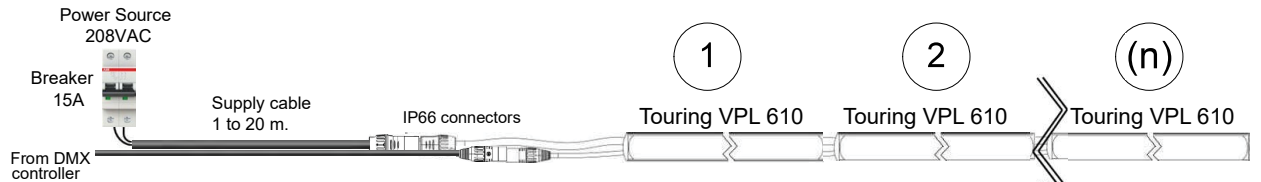

(n) Maximum number of units on a Breaker line				15W		
Power Source nominal voltage	Power Source Shortcircuit current	Cable between Breaker and 1. unit	Cable between each unit	Breaker type 15AC	Breaker type 15AB	Breaker type 15AZ
208 [V]	250 [A]	1 [m]	0 [m]	39	65	65
208 [V]	1000 [A]	1 [m]	0 [m]	65	65	65
208 [V]	250 [A]	10 [m]	0 [m]	25	65	65
208 [V]	1000 [A]	10 [m]	0 [m]	65	65	65
208 [V]	250 [A]	1 [m]	2,5 [m]	8	29	65
208 [V]	1000 [A]	1 [m]	2,5 [m]	18	38	65
208 [V]	250 [A]	10 [m]	2,5 [m]	5	26	65
208 [V]	1000 [A]	10 [m]	2,5 [m]	15	35	65

Optional: Extension cable Between units

Optional: Extension cable Between units

208 VAC/15A - WIRING EXAMPLE TOURING VPL 1220/1FT

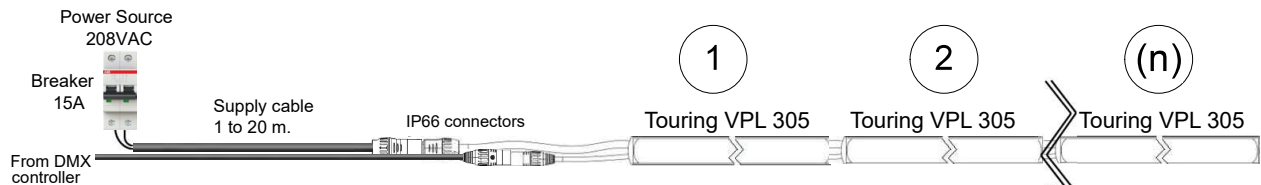

(n) Maximum number of units on a Breaker line				8W		
Power Source nominal voltage	Power Source Shortcircuit current	Cable between Breaker and 1. unit	Cable between each unit	Breaker type 15AC	Breaker type 15AB	Breaker type 15AZ
208 [V]	250 [A]	1 [m]	0 [m]	65	65	65
208 [V]	1000 [A]	1 [m]	0 [m]	65	65	65
208 [V]	250 [A]	10 [m]	0 [m]	51	65	65
208 [V]	1000 [A]	10 [m]	0 [m]	65	65	65
208 [V]	250 [A]	1 [m]	2,5 [m]	9	32	65
208 [V]	1000 [A]	1 [m]	2,5 [m]	20	43	65
208 [V]	250 [A]	10 [m]	2,5 [m]	6	29	65
208 [V]	1000 [A]	10 [m]	2,5 [m]	16	39	65

Optional: Extension cable Between units

Optional: Extension cable Between units

208 VAC/20A - WIRING EXAMPLE TOURING VPL 1220/4FT

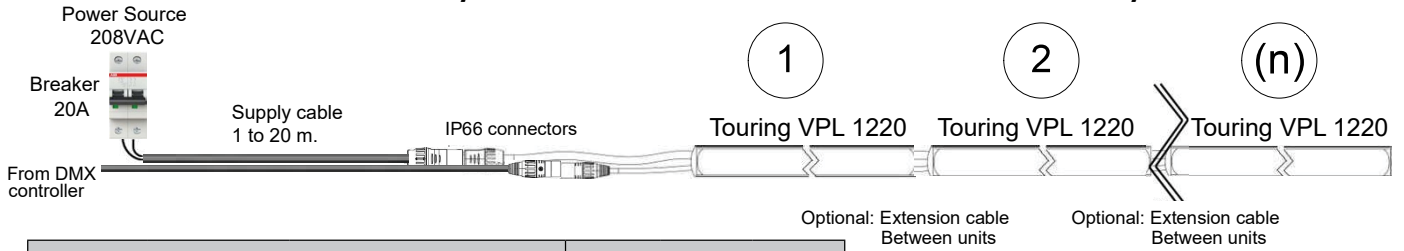

(n) Maximum number of units on a Breaker line				27W		
Power Source nominal voltage	Power Source Shortcircuit current	Cable between Breaker and 1. unit	Cable between each unit	Breaker type 20AC	Breaker type 20AB	Breaker type 20AZ
208 [V]	250 [A]	1 [m]	0 [m]	6	45	65
208 [V]	1000 [A]	1 [m]	0 [m]	30	65	65
208 [V]	250 [A]	10 [m]	0 [m]		38	65
208 [V]	1000 [A]	10 [m]	0 [m]	22	61	65
208 [V]	250 [A]	1 [m]	2,5 [m]	2	15	54
208 [V]	1000 [A]	1 [m]	2,5 [m]	10	23	62
208 [V]	250 [A]	10 [m]	2,5 [m]		13	52
208 [V]	1000 [A]	10 [m]	2,5 [m]	8	21	59

208 VAC/20A - WIRING EXAMPLE TOURING VPL 1220/2FT

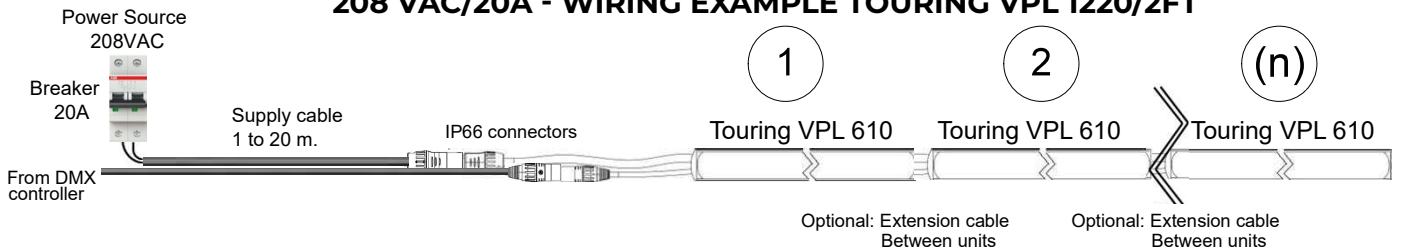

(n) Maximum number of units on a Breaker line				15W		
Power Source nominal voltage	Power Source Shortcircuit current	Cable between Breaker and 1. unit	Cable between each unit	Breaker type 20AC	Breaker type 20AB	Breaker type 20AZ
208 [V]	250 [A]	1 [m]	0 [m]	13	65	65
208 [V]	1000 [A]	1 [m]	0 [m]	60	65	65
208 [V]	250 [A]	10 [m]	0 [m]		65	65
208 [V]	1000 [A]	10 [m]	0 [m]	45	65	65
208 [V]	250 [A]	1 [m]	2,5 [m]	3	19	65
208 [V]	1000 [A]	1 [m]	2,5 [m]	12	28	74
208 [V]	250 [A]	10 [m]	2,5 [m]		16	62
208 [V]	1000 [A]	10 [m]	2,5 [m]	9	25	71

208 VAC/20A - WIRING EXAMPLE TOURING VPL 305/1FT

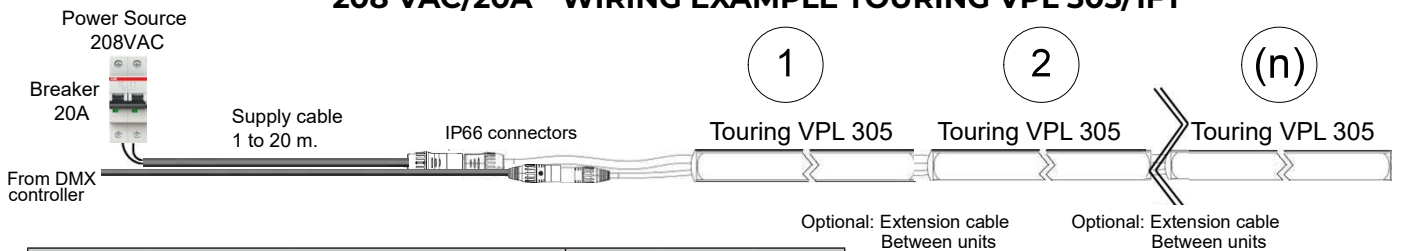

(n) Maximum number of units on a Breaker line				8W		
Power Source nominal voltage	Power Source Shortcircuit current	Cable between Breaker and 1. unit	Cable between each unit	Breaker type 20AC	Breaker type 20AB	Breaker type 20AZ
208 [V]	250 [A]	1 [m]	0 [m]	28	65	65
208 [V]	1000 [A]	1 [m]	0 [m]	65	65	65
208 [V]	250 [A]	10 [m]	0 [m]		65	65
208 [V]	1000 [A]	10 [m]	0 [m]	65	65	65
208 [V]	250 [A]	1 [m]	2,5 [m]	3	21	65
208 [V]	1000 [A]	1 [m]	2,5 [m]	14	31	65
208 [V]	250 [A]	10 [m]	2,5 [m]		18	65
208 [V]	1000 [A]	10 [m]	2,5 [m]	11	28	65

230 VAC/16A - WIRING EXAMPLE TOURING VPL 1220/4FT

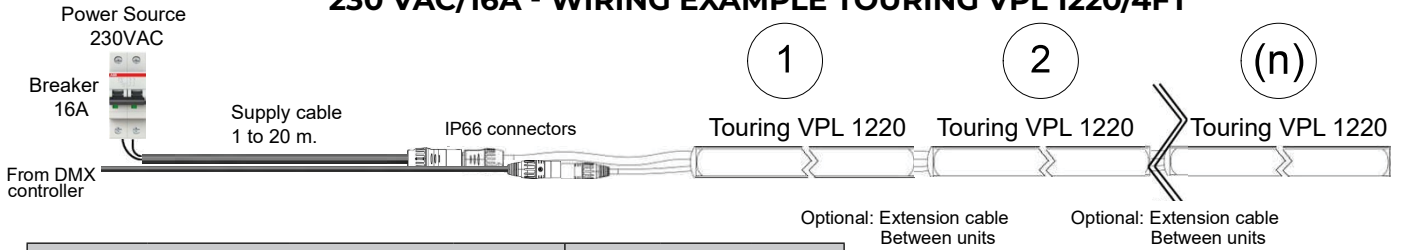

(n) Maximum number of units on a Breaker line				27W		
Power Source nominal voltage	Power Source Shortcircuit current	Cable between Breaker and 1. unit	Cable between each unit	Breaker type 16AC	Breaker type 16AB	Breaker type 16AZ
230 [V]	250 [A]	1 [m]	0 [m]	18	65	65
230 [V]	1000 [A]	1 [m]	0 [m]	44	65	65
230 [V]	250 [A]	10 [m]	0 [m]	11	64	65
230 [V]	1000 [A]	10 [m]	0 [m]	36	65	65
230 [V]	250 [A]	1 [m]	2,5 [m]	6	24	65
230 [V]	1000 [A]	1 [m]	2,5 [m]	15	33	65
230 [V]	250 [A]	10 [m]	2,5 [m]	4	22	65
230 [V]	1000 [A]	10 [m]	2,5 [m]	12	30	65

230 VAC/16A - WIRING EXAMPLE TOURING VPL 610/2FT

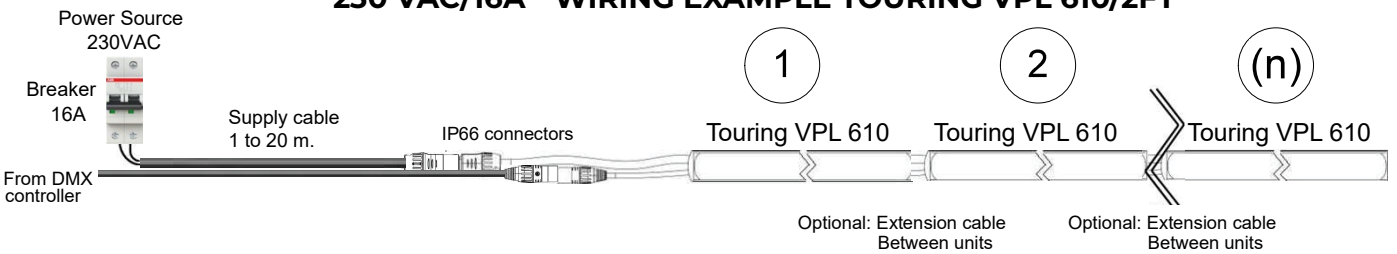

(n) Maximum number of units on a Breaker line				15W		
Power Source nominal voltage	Power Source Shortcircuit current	Cable between Breaker and 1. unit	Cable between each unit	Breaker type 16AC	Breaker type 16AB	Breaker type 16AZ
230 [V]	250 [A]	1 [m]	0 [m]	36	65	65
230 [V]	1000 [A]	1 [m]	0 [m]	65	65	65
230 [V]	250 [A]	10 [m]	0 [m]	22	65	65
230 [V]	1000 [A]	10 [m]	0 [m]	73	65	65
230 [V]	250 [A]	1 [m]	2,5 [m]	8	29	65
230 [V]	1000 [A]	1 [m]	2,5 [m]	18	39	65
230 [V]	250 [A]	10 [m]	2,5 [m]	5	26	65
230 [V]	1000 [A]	10 [m]	2,5 [m]	15	37	65

230 VAC/16A - WIRING EXAMPLE TOURING VPL 305/1FT

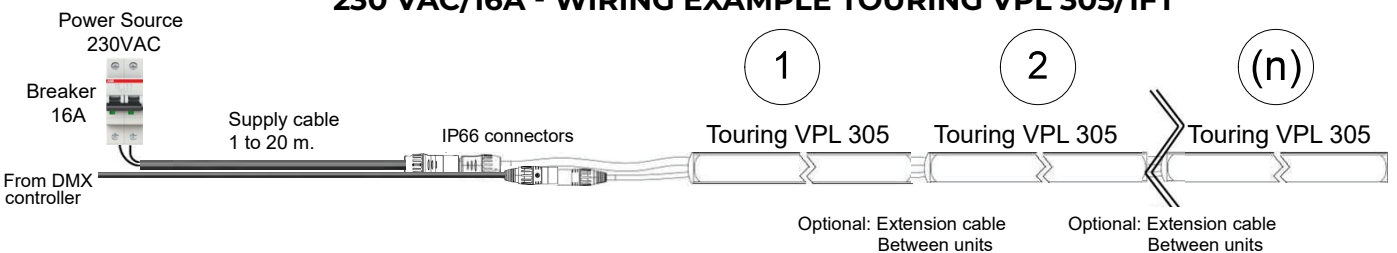

(n) Maximum number of units on a Breaker line				8W		
Power Source nominal voltage	Power Source Shortcircuit current	Cable between Breaker and 1. unit	Cable between each unit	Breaker type 16AC	Breaker type 16AB	Breaker type 16AZ
230 [V]	250 [A]	1 [m]	0 [m]	65	65	65
230 [V]	1000 [A]	1 [m]	0 [m]	65	65	65
230 [V]	250 [A]	10 [m]	0 [m]	45	65	65
230 [V]	1000 [A]	10 [m]	0 [m]	65	65	65
230 [V]	250 [A]	1 [m]	2,5 [m]	18	32	65
230 [V]	1000 [A]	1 [m]	2,5 [m]	42	44	65
230 [V]	250 [A]	10 [m]	2,5 [m]	5	29	65
230 [V]	1000 [A]	10 [m]	2,5 [m]	17	41	65

The VPL is intended to be set up for use prior to programming using the SGM Network Admin software available for PC. Using the Admin software, the VPL system is designed for easy installation and patching. For detailed instructions and guidance on setup and configuration, please refer to the SGM Network Admin. The software and manual for the SGM Network Admin is available at www.sgmlight.com.

It is recommended that any network design and installation be facilitated by trained and experienced personnel with the programming and use of pixel control products. SGM recommends to always use dedicated professional networks, instead of standard corporate networks.

NETWORK SETUP

The VPL fixtures can work properly in a wide array of network setups. Depending on the size of your network and installation, there may be further considerations to effectively manage the data traffic of large scale RGB pixel style control.

If possible, SGM advises keeping VPL networks separated from general building networks or using VLAN's to avoid excess network traffic. Networked data traffic for pixel control is not suitable for typical TCP/IP network settings and often is not able to be managed effectively with general IT personnel.

VPLs address themselves automatically in the 2.x.x.x /8 range on start-up. This method has been designed to make setup easier and to optimize the reliability of the system. It is possible to change the IP address if necessary.

The VPL product line receives and transmits information via sACN or Art-Net ethernet protocols. Both are Universal Datagram Packet (UDP) type protocols. UDP protocol can be networked in the same topology as TCP, but there are some important considerations for effectively routing and managing UDP in a large full-duplex network.

Art-Net, sACN, and Broadcasting Considerations

sACN and Art-Net are communication protocols developed to transport DMX512 data over an Ethernet network. Both sACN and Art-Net can utilize Broadcast, Unicast, or Multicast, but there are some important differences in how they can use these casting types.

Art-Net

By default an Art-Net product will factory start using a Class A IP address scheme in the 2.x.x.x range, since this allows Art-Net products to communicate directly and without the need for a DHCP server to be connected to the network. This is also the case of VPLs.

In large installations, especially ones utilizing ACN (Architecture for Control Networks), it is important to note that Art-Net cannot offset DMX512 universes and cannot be put into different ACN ranges.

sACN

sACN (or ANSI E1.31 – 2016) is primarily intended to use multicast. Network switches have differing levels of support for multicasting. To handle multicast data correctly, a switch needs to know which multicast subscribers are attached to which of its physical ports. It obtains this information by monitoring IGMP packets. If the switch does not see these packets, it will either treat the packets as unwanted and block them, or convert the packets to broadcast.

This is important because the maximum number of sACN DMX512 universes is 63,999. An unintended broadcast of that much data can take down everything connected to the network, large or small.

The VPLs are by default in the 2.x.x.x range but that range can be changed. The network still needs to be configured to the same range the VPLs are in.

IGMP

Multicast requires some additional network management on the part of the controller and receiver. VPL uses Internet Group Management Protocol (IGMP) version 3 for this management. In a VPL network, controllers and connected equipment must support IGMP v3 to manage the subscription of multicast addresses in network routers.

For more information on:

Art-Net, please see <https://art-net.org.uk/>

- sACN (ANSI E1.31 – 2016) or,
- RDM (ANSI E1.20 – 2010) or,
- DMX512 (ANSI E1.11 - 2008 (R2018)) please see TSP (esta.org)

UNIVERSAL DATAGRAM PACKET (UDP)

UDP is used for entertainment lighting data because it is fast. Speed and timing are critical in creating coordinated, instant changes in a pixel array. Network infrastructure products such as switches are typically designed for TCP/IP packet traffic with occasional UDP data. They also expect to see the majority of data as unicast. Lighting control networks often contain mainly UDP and can contain a significant percentage of broadcast data.

In Full-Duplex networks, The TCP and UDP protocols are part of the IP layer. Both TCP and IP have their own flow control techniques. However, the TCP and IP methods of flow control are oblivious of each other and having both enabled on a network can lead to problems. For this reason, many ethernet switch manufacturers ship their products with IP flow control disabled, assuming that TCP will handle its own flow control. That assumption is fair in an office environment. However, entertainment networks tend to be primarily UDP which does not have any flow control. SGM recommends to enable IP based flow control if possible.

NETWORK SIZE

SGM does not specify a preferred topology for a network. However, in large networks, the introduction of routers and extra switches can introduce data delays on the signal path. It is recommended to incorporate a minimum of devices between the lighting data controller and the VPL installation.

VPLs can make use of Rapid Spanning Tree if desired. However, the above applies if the signal path is lengthened or routed in a significantly different way in the event of a path change. See later in this manual for details on how Rapid Spanning Tree is handled.

FIXTURE PROPERTIES

FACTORY DEFAULT

From the admin tool the factory default settings can be re-initialized. This can be set for each available VPL or all VPL's - even when the VPL's are located in another IP range.

Hall sensor input on the actual VPL can be activated with a magnet. On the trailing edge of an activation the state is shifted one position.

State 1 - RED LED's test

State 2 - GREEN LED's test

State 3 - BLUE LED's test

State 4 - WHITE LED's test

State 5 - GREEN LED count sequence. Hall sensor activation for 10 seconds = VPL will re-initialize factory defaults and restart.

LENSES AND LENS ACCESSORIES

The direct view of the VPLs can be modified with snap-on lenses.

VPL Opal Lens

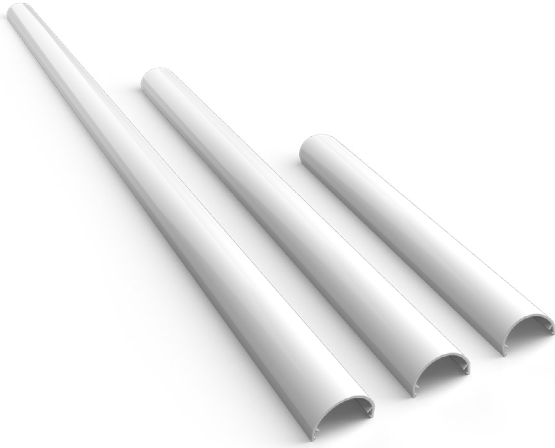

Smoked frosted Lens

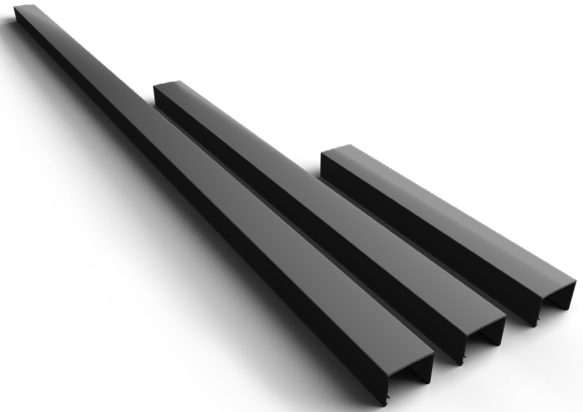

VPL Rounded Smoked Opal lens

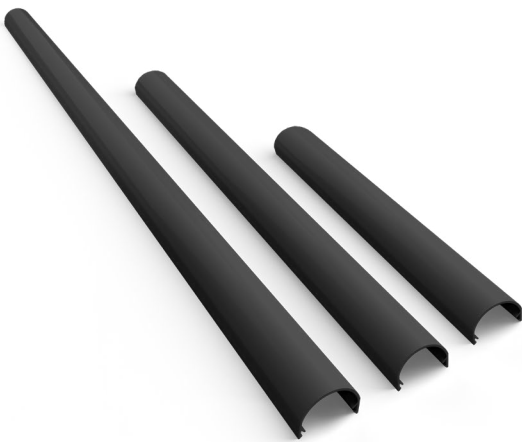

VPL Opal/Black Lens

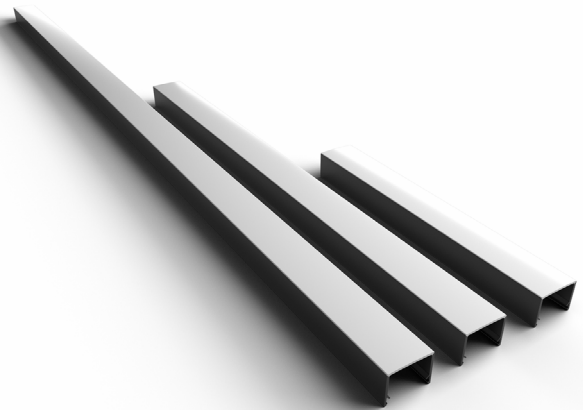

Smoked clear Lens

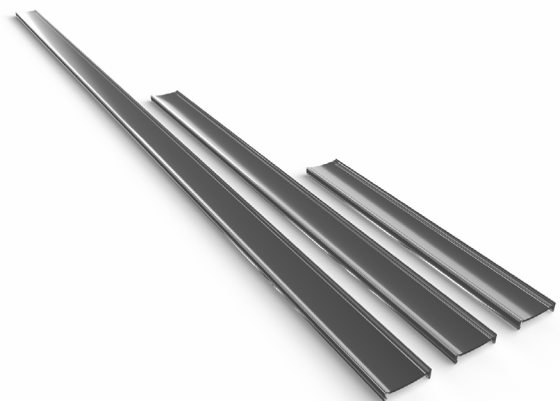

REMOVING A LENS

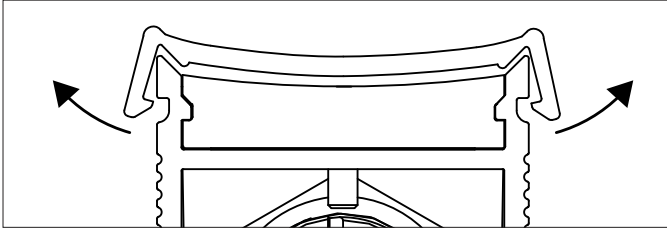

Figure 24: Open lens-hooks

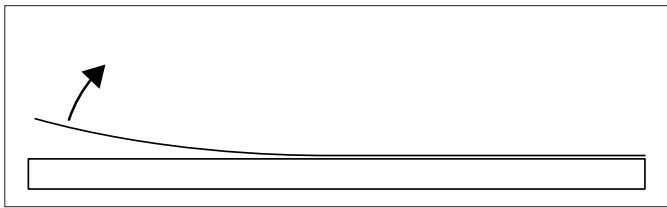

Figure 25: Lift up the VPL lens

The best way to remove a VPL lens is to open the hooks at the profile and lift the lens up. We strongly recommend not to use any metal tools in the process as these can damage both the VPL lens, the VPL aluminium profile, the optical silicone and, in worst case, the LEDs, which will result in a reduced Ingress Protection.

CUTTING A VPL LENS

When adjusting the length of a VPL lens, it is recommended to use a fine-toothed saw (a blade with 24 or more teeth per inch) like a hacksaw. Keep in mind that when sawing by hand it is recommended to use a mitre box and driving the saw as horizontal as possible (see figure 26). When the lens has been cut, some plastic shavings might remain on the lens, which can be removed with a sharp edge or knife (see figure 27).

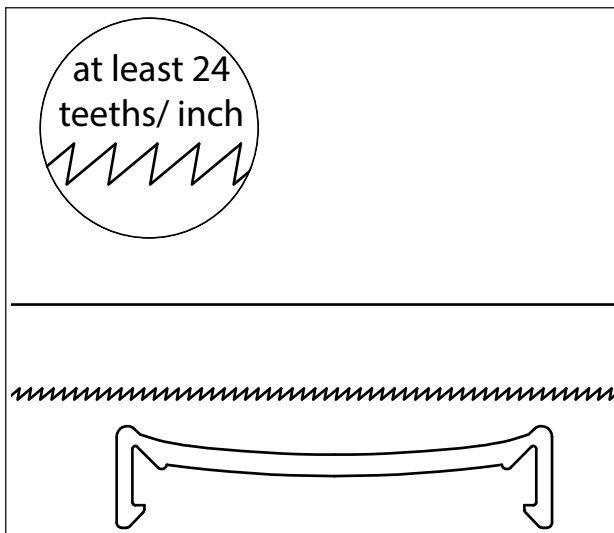

Figure 26: Cutting the lens horizontally

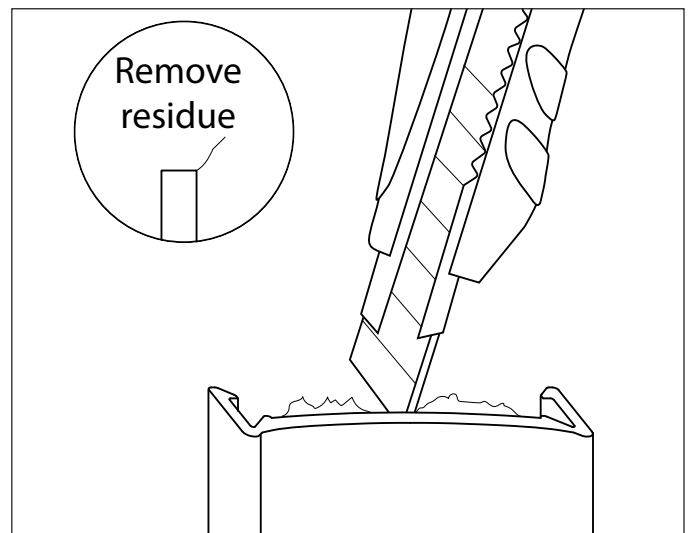
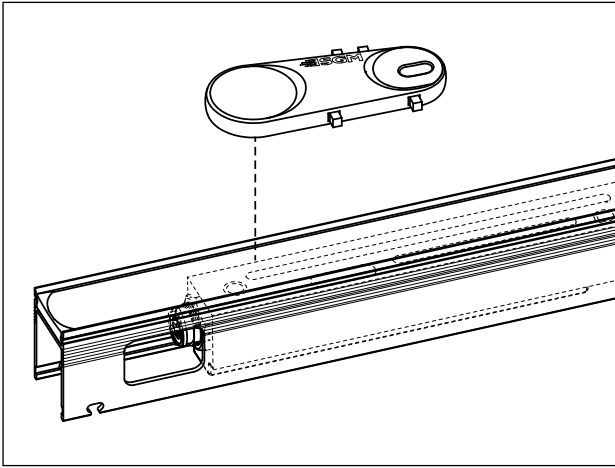

Figure 27: removing left-over shavings

FACTORY DEFAULT WITH MAGNET



To test a VPL, touch the VPL at the soldered power and data terminal connections with a powerful magnet or the SGM Spanner key/magnet (see figure 28). By touching the magnet 4 times, the fixture will cycle through R,G,B and W. If a contact is made for a 5th time, the first 10 pixels will sequentially start turning on in green, one pixel per second. Once all 10 pixels light up in green, the fixture will perform a total factory reset. This includes DMX Address/Universe/IP Address/Mode/Name/Dark Boot/Flip/and Color Calibration Setting. This can be used to troubleshoot the fixture and check it is receiving power.

Figure 28: Functionality test of VPL

PROBLEM	POTENTIAL CAUSE(S)	REMEDIES
Fixture does not respond or appears to be off.	No power to the fixture. (The fixture does not react when touching the soldered terminals with a magnet)	Confirm that the power is switched on, that the cables are plugged in, and the power connector is inserted and turned to its locked position.
	No data to the fixture (The fixture reacts to touching the soldered terminals with a magnet)	Confirm that the cables are plugged in and the power connector is inserted and turned to its locked position.
Fixture suddenly turned off.	Power was turned off.	Check the switches and breakers.
	Data connection was disconnected.	Inspect data cables.
If the problem is not solved, please contact SGM support via: support@sgmlight.com or through your local SGM distributor.		

MAINTENANCE

The only maintenance related to the VPLs is periodical exterior cleaning and occasional update of the firmware.

UPGRADING THE FIRMWARE

The installation of the upgrade is done through the SGM Network Admin tool. To execute the installation please see the SGM Network Admin manual.

The latest firmware, manuals and the SGM Network Admin tools are all available for free download on SGM's webpage: www.sgmlight.com, if in any doubt, please contact SGM support at: support@sgmlight.com.

CLEANING

SGM fixtures with an IP66-rating do not require cleaning procedures inside the fixture. However, cleaning the optical silicone may be needed to achieve the maximum light output after exposure to dust, sand, or dirt.

Whenever necessary, clean the VPL using a soft cloth dampened with water. For a thorough cleaning of the exterior, the use of a plastic cleaner such as SONAX PROFILINE Interior Plastic Cleaner is recommended. Do not use products that contain solvents, abrasives, or caustic agents for cleaning, as they can cause damage to hardware, cables, and connectors. Consult www.sgmlight.com or contact SGM Light support if you have any questions regarding cleaning and maintenance.

Cleaning will vary greatly depending on the operating environment and installation. It should therefore be checked at frequent intervals within the first few weeks of operation to see how often cleaning is necessary.

FIXTURES AND ACCESSORIES

PLEASE NOTE! THE LIST BELOW IS SUBJECT TO CHANGE WITHOUT NOTICE.

The VPL Series can be used with a variety of accessories.

Contact your local SGM dealer to get the latest pricing and news about available accessories.

Please note: the products listed below are subject to change without notice.

ORDERING INFORMATION

Touring VPL 305-20 BL	P/N: 80080060
Touring VPL 610-20 BL	P/N: 80080061
Touring VPL 1220-20 BL	P/N: 80080062
VPL 305-20	P/N: 80080052
VPL 610-20	P/N: 80080055
VPL 1220-20	P/N: 80080053

VPL ACCESSORIES

Link Plate	P/N: 83060717
Pivot Bracket	P/N: 83060718
Slimline Touring Clamp	P/N: 83060722
VP cable 1m	P/N: 07860249
VP cable 2,5m	P/N: 07860250
VP cable 5m	P/N: 07860251
VP cable kit 1m	P/N: 83062054
VP cable kit 10m	P/N: 83062055
Crimping tool for VP connector	P/N: 83062301
VP Power + Data Joiner	P/N: 83062046
VP Touring Power + Data joiner	P/N: 83062049
VPL Dual installation bracket	P/N: 83060635
VPL Single installation bracket	P/N: 83060634
VPL Touring bracket	P/N: 83060633
VP Power inserter	P/N: 83062047
VP Connector End cap	P/N: 83062056
VPL GND/Earth wire kit	P/N: 83062050
Waterproof RJ-45 Kit	P/N: 83062057

VPL LENSES

VPL Lens Opal 305	P/N: 83061070
VPL Lens Opal 610	P/N: 83061072
VPL Lens Opal 1220	P/N: 83061074
VPL Lens Opal 1330	P/N: 83061076
VPL Smoked clear 305	P/N: 83061077
VPL Smoked clear 610	P/N: 83061078

VPL Smoked clear 1220	P/N: 83061079
VPL Smoked clear 1330	P/N: 83061080
VPL Opal/Black 305	P/N: 83061081
VPL Opal/Black 610	P/N: 83061082
VPL Opal/Black 1220	P/N: 83061083
VPL Opal/Black 1330	P/N: 83061084
VPL Smoked Frosted Lens 305	P/N: 83061085
VPL Smoked Frosted Lens 610	P/N: 83061086
VPL Smoked Frosted Lens 1220	P/N: 83061087
VPL Rounded Smoked Frosted Opal 305	P/N: 83061089
VPL Rounded Smoked Frosted Opal 610	P/N: 83061090
VPL Rounded Smoked Frosted Opal 1220	P/N: 83061091

SUPPORT HOTLINE

SGM offers 24/7 technical support.

Worldwide: +45 3840 3840

US: +1 407-242-6217

support@sgmlight.com

APPROVALS AND CERTIFICATIONS

Conforms to	2014/35/EU: Low Voltage Directive
Conforms to	2014/30/EU: EMC Directive
Conforms to	2011/65/EU: RoHS2 Directive
Certified to	CAN/CSA Std. CSA E60598-1 Ed:2
Certified to	CAN/CSA Std. CSA-E598-2-17-98 Ed:1
Certified to	UL Std. 1573
Conforms to	UK SI 2016 No. 1101: The Electric Equipment (Safety) Regulations 2016
Conforms to	UK SI 2016 No. 1091: Electromagnetic Compatibility Regulations 2016
Conforms to	UK SI 2012 No. 3032: Restriction of the Use of Certain Hazardous Substances in Electrical and Electronic Equipment Regulations 2012 (RoHS2)

The information in this document is subject to change without notice.
For the latest information, visit www.sgmlight.com.





SGM LIGHT A/S

Sommervej 23

8210 Aarhus V

Denmark

Tel: +45 70 20 74 00

info@sgmlight.com

www.sgmlight.com